

Smart temperature transmitter APT-2000ALW

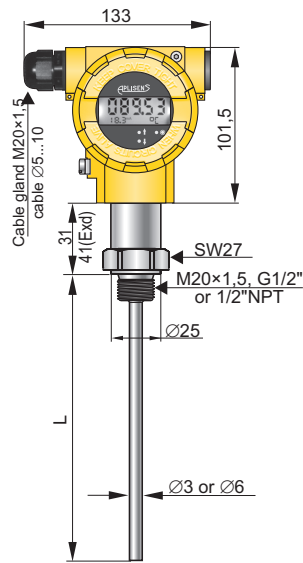

- ✓ 4...20 mA output signal + HART protocol
- ✓ Programmable range, zero shift, characteristic and damping ratio with local panel keys
- ✓ Intrinsic safety (ATEX), Explosion proof (ATEX, IECEx) version
- ✓ Resistant or thermocouple measuring element
- ✓ MID (Measuring Instruments Directive) – certificate acc. to 2004/22/WE directive and OIML R140:2007 recommendations.



APT-2000ALW/GB

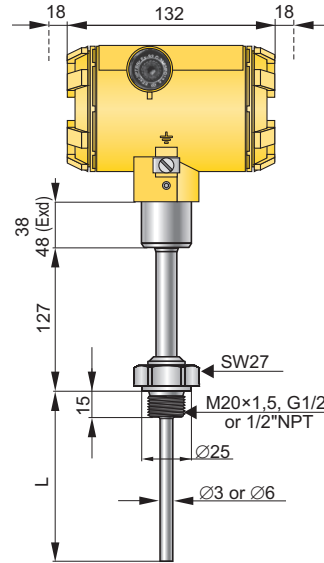

APT-2000ALW/GN

Thermowell

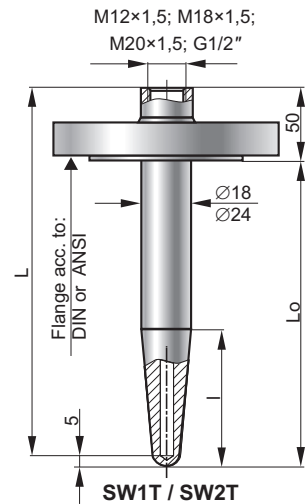
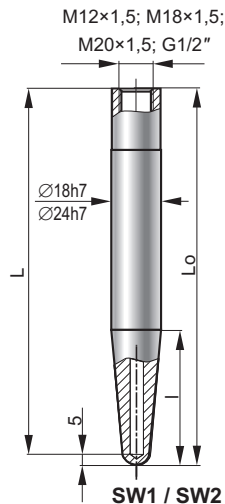
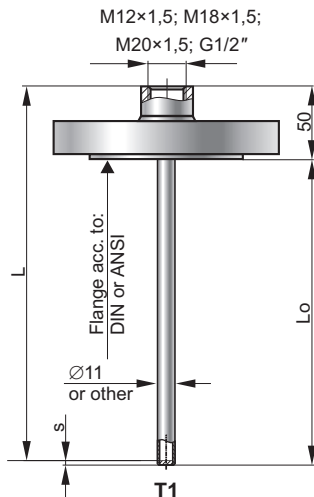
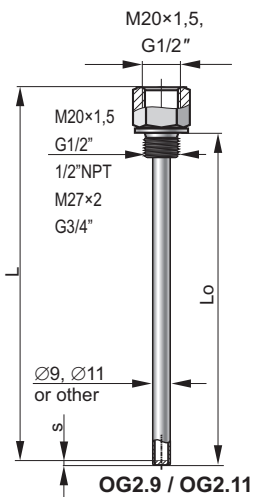

Technical data

Metrological parameters

Error (digital value)

Standard version:

- ± (0,2 + 0,002·|t|)°C for Pt100
- ± 1,5°C for TC K and t ≤ 375°C
- ± (0,004·t)°C for TC K and t > 375°C

Version with better accuracy (version KT):

- ± (0,05 + 0,05%·z + 0,001·|t|)°C for Pt100
- ± (0,5 + 0,05%·z)°C for TC K and t ≤ 375°C
- ± (0,5 + 0,05%·z + 0,002·(t-375))°C for TC K and t > 375°C

Additional error for analog output ±0,04%·z

where:

|t| – absolute value of the measured temperature °C

t – value of the measured temperature °C

z – transmitter setting range °C

Measuring range

Sensor type	Min set range	Nominal range
Pt100	10°C	-70...500°C*
K	10°C	-40...550°C

* for GB version -50...150°C

Electrical parameters

Power supply 12...55 V DC (Ex 13,5...28 V)

Additional voltage drop when display illumination switched on 3 V

Output signal 4...20 mA + Hart protocol

Resistance required for communication (HART) min. 240Ω

Load resistance

$$R[\Omega] = \frac{U_{zas}[V] - 12V}{0,0225A}$$

* – 15 V when display illumination switched on

Operating conditions

Ambient temperature
 for version with Ex ia -40...85°C
 for version with Ex d -40...80°C
 for version with Ex d -40...75°C

Min. immersion length

L=100mm

Casing

Materials

Aluminum,
 316Lss- special version
 321ss
 according to table page.

Sensor material Thermowell

Communication and configuration

The communication standard for data interchange with the transmitter is the Hart protocol.

Communication with the transmitter is carried out with:

- Hart type communicators,
- a PC using an HART/USB converter and Report 2 configuration software.

The data interchange with the transmitter enables the users to:

- identify the transmitter;
- configure the output parameters;
- read the currently measured temperature value of the output current and the percentage output control level;
- force an output current with a set value;
- calibrate the transmitter in relation to a model temperature.

Standard thermowell data

Thermowell type		Standard dimensions of thermowell						Thermowell material	Available process connection	
		Ø[mm]		L[mm]		l[mm]				
OG2.9		9x1		100, 160, 250, 400		-		316Lss	M20x1,5; G1/2"; 1/2"NPT	
OG2.11		11x2		100, 160, 250, 400		-		316Lss	M20x1,5; G1/2"; 1/2"NPT	
T1		11x2		100, 160, 250, 400		-		316Lss	Flange according to DIN and ANSI	
SW1	SW2	18h7	24h7	100 140 200	140 200	35 65 65	65 65	15HM, 10H2M 316Lss	-	
SW1T	SW2T	18h7	24h7	100 140 200	140 200	35 65 65	65 65	15HM, 10H2M 316Lss	Flange according to DIN and ANSI	
SW1G	SW2G	18h7	24h7	100 140 200	140 200	35 65 65	65 65	15HM, 10H2M 316Lss	M20x1,5, G1/2"	M27x1,5, G3/4"

Ordering procedure

APT-2000ALW/___/___/___/___/ L = mm / ___ / ___ ÷ ___ °C / ___ / ___

Special version:

Exia - ATEX certificate

⊕ II 1/2G Ex ia IIC T4/T5/T6 Ga/Gb

Exia(Da) - ATEX certificate

⊕ II 1/2G Ex ia IIC T4/T5/T6 Ga/Gb
II 1D Ex ia IIC T105°C Da
I M1 Ex ia I Ma (version with SS housing)

Exd - ATEX certificate

⊕ II 1/2G Ex ia/d IIC T* Ga/Gb
II 1/2D Ex ia/t IIIC T* Da/Db
I M2 Exd ia I Mb (version with SS housing)

IECEX

Ex ia/d IIC T* Ga/Gb
Ex ia/t IIIC T* Da/Db
Wx ia I Mb (version with SS housing)

T* - temperature class transmitter (for gas)
or maximum surface temperature (for dust)

SS - Housing material 316SS

KT - execution with higher accuracy

IP67, IP66/67

Version: **GB, GN**

Thermowell type: according to table

Type of thread of flange connection:

M20x1,5; G1/2"; 1/2"NPT or flange

Immersion length

Type of measuring element: **Pt100, K**

Set measuring range

Alarm signal: 3,8 or 23 mA

Electrical connection: **without marking** (M20x1,5) or **US** (1/2"NPTF)

SMART TEMPERATURE TRANSMITTER APT-2000ALW with MID

Application

Smart temperature transmitters APT-2000ALW MID is applicable to the measurement of the temperature in application designed according to directive 2004/22/WE (MID), harmonized standard PN-EN12405-1:2005 + A2:2010 and recommendation OIML R140:2007. Device subcomponent suitable for custody transfer measurement of gas with MID approval. Mechanical construction and installation of the transmitter enclosure shall comply with the transmitter APT-2000ALW are described on page IX/ 2, IX/ 3 of catalogue. Transmitter due to factory blockade of transmitter's configuration cannot be configurable by user. Electrical connection of the transmitter is according to drawing on page IX/ 3. Available are only terminals SIGNAL + and SIGNAL -. Temperature transmitter APT-2000ALW MID are produce with GB type of sensor and with resistant sensor Pt100.

Metrological parameters

Max. permissible error according to EN12405-1 (calculated in relation to the measured value)

- in reference conditions	
20±3°C(±1 during the measurement)	≤ 0,1%
- nominal operating conditions	< 0,2%
special version	< 0,1%
Long-term stability	< 0,2% / 5 years
Operating temperature range	-25...55°C
Immersion length	150...290mm
Power supply	Exia: 13,5...28VDC Exd: 13,5...45VDC

MID Parts Certificate No. 28/12

Exia: ⊕ II 1/2G Ex ia IIC T4/T5/T6 Ga/Gb

Exd: ⊕ II 1/2G Ex ia/d IIC T* Ga

Measuring range

Measuring range: -20...60°C

Ordering procedure

APT-2000ALW/MID/___/___/ L = mm

Special version:

Exia - Intrinsic safety version (ATEX)

Exd - Explosion proof version (ATEX)

SS - Housing material 316SS

Process connection type: **M20x1,5, G1/2"**

Immersion length

Smart temperature transmitter LI-24ALW



- ✓ Output signal 4...20mA with Hart protocol
- ✓ Galvanic insulation (In, Out)
- ✓ Programmable sensor type
- ✓ Programmable measuring range
- ✓ Thermoresistance line compensation
- ✓ Compensation of thermocouple cold junction
- ✓ Autodiagnostic system
- ✓ Intrinsic safety certificate (ATEX, IECEx)
- ✓ Explosion proof certificate (ATEX, IECEx)
- ✓ Safety version SIL2/SIL3

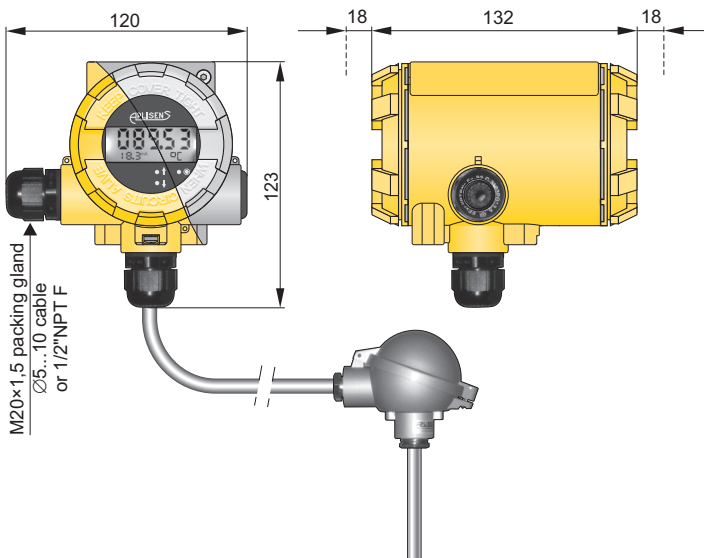

LI-24ALW with remote mounted temperature sensor

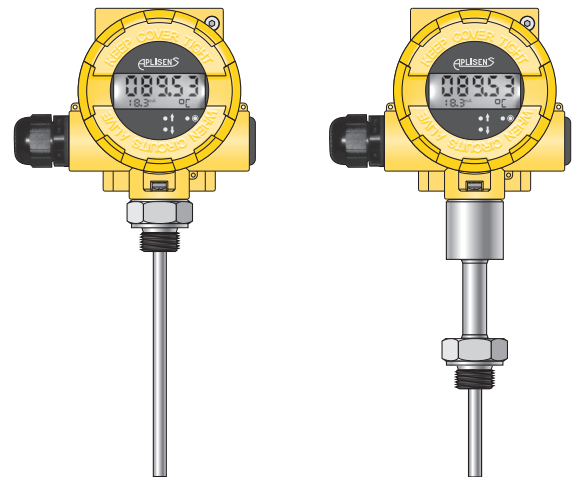

LI-24ALW with direct mounted temperature sensor

Application and function

The temperature transmitter LI-24ALW is applicable to converting resistance of temperature or voltage of thermocouple sensor to standard current signal 4-20mA. The transmitter has two separate channels enabling measurement of temperature difference, average, average with redundancy, max. or min. temperature. Transmitter has compensation of ambient temperature influence and compensation of thermocouple cold junction using internal/external (Pt100) sensor or constant temperature. Most of parameters such as: sensor type, measuring range, current alarm signal when electric circuit is broken, output characteristic correction, user characteristic (60 points) are programmed using PC with HART/USB converter and Aplisens RAPORT 2 configuration software. For request Aplisens can set temperature transmitter parameters like measuring range, type of sensor. Their values are printed on label. Transmitter LI-24/ALW is designed for field use. LI-24ALW can be used with temperature sensors mounted directly in transmitter's casing or with external sensors connected with cable.

Technical data

Input signal	Resistance: Pt100, Ni100 Voltage: K, J, S, B, N, T, R, E
Limit process	-10mV < E < 100mV or -100mV < E < 1000mV 0Ω < R < 400Ω or 0Ω < R < 2000Ω
Min. measuring range	10mV or 10Ω or 10K
Output signal	4 - 20 mA + Hart 13,5*...55 VDC Exia: 13,5*...30 VDC Exd: 13,5*...45 VDC Safety, Safety Exd: 12,5...36 VDC Safety Exia: 12,5...30 VDC
Power supply	*- with display illumination switched on +3V, display backlight can be switched on only during production
Max. wires resistance	500Ω
Alarm signal	3,75mA / 21,5mA (NORMAL) or 3,6 mA / 21 mA (NAMUR NE89) or setting by user
Sensor current	0,42mA Safety: 0,25mA
Galvanic insulation	Optoelectrical
Accuracy	acc. to below table
Time constant	0,3s
Additional electronic damping	0..30s
Ambient temperature	-40...+80°C Exia: -40...+80°C Exd: -40...+75°C Safety: -40...+85°C Safety Exia, Safety Exd: -40...+75°C

LI-24ALW/Safety can be programmed only with HART protocol. Local buttons allows only to change display settings.

Type of input signals and metrological parameters

RTD sensors			Thermocouples		
Thermal resistance sensors	2, 3 or 4 wires connection		Input impedance	>10MΩ	
Sensor current	~250 μA		Maximum wires resistance	500 Ω (wires + thermocouple)	
Maximum wires resistance	25 Ω		Cold junctions compensation	Internal sensor, external sensor Pt100, constant value	
Sensor type	Basic range (FSO)	Min. range span	Sensor type	Basic range (FSO)	Min. range span
	°C	K		°C	K
Pt100	-200+850	10	B	500+1820	50
Pt200	-200+850	10	E	-150+1000	50
Pt500	-200+850	10	J	-210+1200	50
Pt1000	-200+266	10	K	-150+1372	50
Ni100	-60+180	10	N	-150+1300	50
Cu100	-50+180	10	R	50+1768	50
			S	50+1768	50
			T	-150+400	50
Resistance (resistor, potentiometer)			Czujnik wewnętrzny CJC	-	
			Voltage		
	Ω	Ω		mV	mV
Measuring range No.1	0+400	10	Measuring range No.1	-10+100	10
Measuring range No. 2	0+2000	10	Measuring range No. 2	-100+1000	10

Electrical diagrams

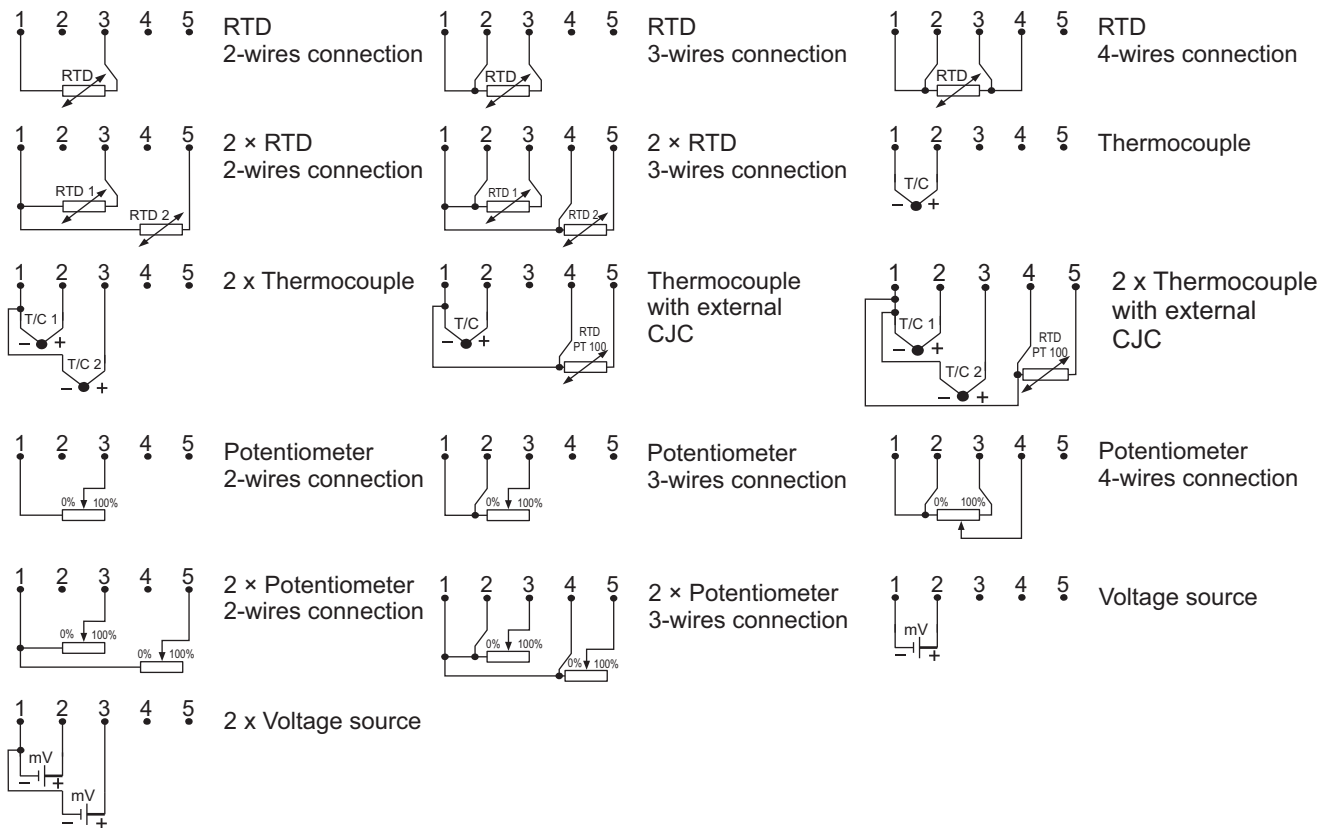

Direct mounted sensors

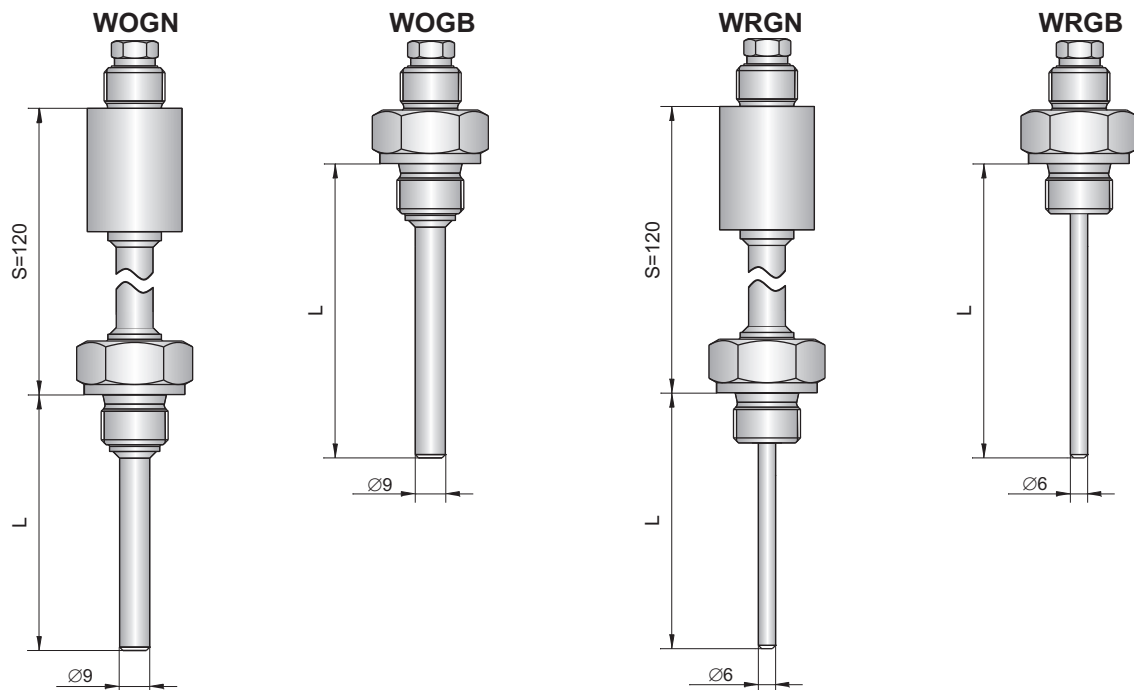

Sensor type	Standard dimensions of sensor			Sensor material	Available process connection
	Ø[mm]	L[mm]	S[mm]		
WOGN	9	100, 160, 250, 400	120	316ss	M20x1,5; G1/2"; 1/2"NPT
WOGB	9	100, 160, 250, 400	-	316ss	M20x1,5; G1/2"; 1/2"NPT
WRGN	6	100, 160, 250, 400	120	316ss	M20x1,5; G1/2"
WRGB	6	100, 160, 250, 400	-	316ss	M20x1,5; G1/2"

WOGN, WOGB - welded sensors; WRGN, WRGB - spring-loaded sensors (to use with additional thermowell)

Ordering code

Model	Code	Description
LI-24		Smart pressure transmitter
Versions	/ALW.....	With display, output 4-20mA + Hart
	/ALW/Safety.....	With display, output 4-20mA + Hart Functional Safety certificate according to PN-EN 61508:2010 parts 1 + 7, PN-EN 61511-1:2017-07 + PN-EN 61511-1:2017/A1:2018-03, PN-EN 62061:2008 + PN-EN 62061:2008/A1:2013-06 + PN-EN 62061:2008/A2:2016-01
Certificates, options*	/SS.....	Stainless steel housing
	/Exia.....	<p>II 2(1)G Ex ia [ia Ga] IIC T4/T5/T6 Gb II 1/2G Ex ia IIC T4/T5/T6 Ga/Gb (with direct sensor)</p> <p>Ex</p> <p>Safety version: II 2(1)G Ex ia [ia Ga] IIC T4 Gb</p> <p>Ex ia [ia Ga] IIC T4/T5/T6 Gb Ex ia IIC T4/T5/T6 Ga/Gb (with direct sensor)</p> <p>IECEx</p> <p>Safety version: Ex ia [ia Ga] IIC T4 Gb</p>
	/Exia (Da).....	<p>II 2(1)G Ex ia [ia Ga] IIC T4 Gb II 1D Ex ia IIIC T105°C Da I M1 Ex ia I Ma (with 316ss case)</p> <p>Ex</p> <p>Ex ia [ia Ga] IIC T4 Gb Ex ia IIIC T105°C Da Ex ia I Ma (with 316ss case)</p> <p>IECEx</p>
	/Exd.....	<p>With remote sensor: II 2(1)G Ex db [ia Ga] IIC T5/T6 Gb II 2(1)D Ex tb [ia Da] IIIC T100°C/T85°C Db I M2 Ex db [ia Ma] I Mb (with 316ss case)</p> <p>Ex</p> <p>With direct sensor WO.../WR...: II 2G Ex db IIC T**/T5/T6 Gb II 2D Ex tb IIIC T*/T100°C/T85°C Db I M2 Ex db I Mb (with 316ss case)</p> <p>Safety version: II 2G Ex db IIC T**/T5/T6 Gb II 2D Ex tb IIIC T*/T100°C/T85°C Db I M2 Ex db I Mb (with 316ss case)</p> <p>With remote sensor: Ex db [ia Ga] IIC T5/T6 Gb Ex tb [ia Da] IIIC T100°C/T85°C Db Ex db [ia Ma] I Mb (with 316ss case)</p> <p>IECEx</p> <p>With direct sensor WO.../WR...: Ex db IIC T**/T5/T6 Gb Ex tb IIIC T*/T100°C/T85°C Db Ex db I Mb (with 316ss case)</p> <p>Safety version: Ex db IIC T**/T5/T6 Gb Ex tb IIIC T*/T100°C/T85°C Db Ex db I Mb (with 316ss case)</p>
* more than one option is available	/IP67.....	Protection class IP67
	/US.....	Electrical and sensor connection "NPTF"
Type of measuring element	/.....	Type of measuring element according to tables from page IX/7
Measuring set range	/.....	Measuring range
Sensor type (optionally)	/.....	Without sensor
	/code of direct sensor	Direct mounted sensor according to below table

Packing gland available on request

Type of sensor	WOGN.....	Sensor with threaded process connection, diameter of sensor 9mm, neck S=120mm, wetted parts 316ss
	WOGB.....	Sensor with threaded process connection, diameter of sensor 9mm, 316ss
	WRGN.....	Spring loaded sensor with threaded process connection, neck S=120mm, wetted parts 316ss
	WRGB.....	Spring loaded sensor with threaded process connection, wetted parts 316ss
Special version	/Exia.....	Intrinsic safe version
	/Exd.....	Explosion proof version
Length of sensor	/L=...mm	Required length of immersion [mm]
Neck extension	/S=...mm	Required length of neck [mm] (if different than standard)
Process connection		Thread type
Type of measuring element		Type of measuring element
Sensor material		Sensor material (if different than standard)
Connection thread between sensor and transmitter		Thread between sensor and transmitter

NEW

Temperature transmitter type PT-25

- ✓ Output signal 4 ÷ 20mA
- ✓ Stainless steel casing and wetted parts
- ✓ Factory configured

Application and construction

Temperature transmitter type PT-25 is designed for temperature measurement of liquid and gaseous media in range from -50 to +100°C. Resistance signal from RTD element is converted to standard 4...20mA output signal. Casing of transmitter and wetted parts are made in stainless steel. Transmitter is manufactured in two versions: with removable measuring insert and not removable measuring insert which has additional protection against vibrations. Available electrical connections are angular connector DIN EN 175301-803 or connector M12x1.

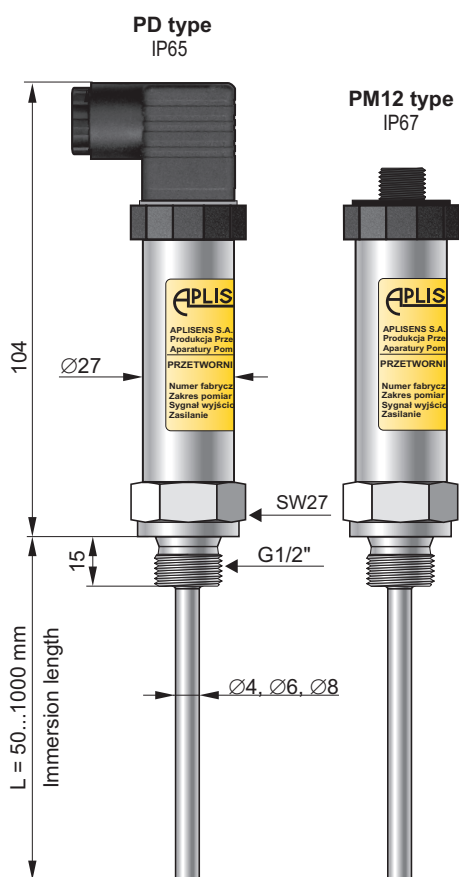

Technical data

Output signal	4...20mA
Measuring range	0...50°C, 0...100°C, -50...50°C, -50...100°C, 25...75°C, 50...100°C other on request
Minimum span	25K
Accuracy	± 1%
Power supply	8...35 V DC
Alarm signal	<3,1mA or >26,1mA
Wetted parts material	316
Sensor diameter	Ø4, Ø6, Ø8mm
Process connection	G1/2", other on request
Immersion length	50...1000mm
Extension neck	on request
Ingress protection	PD - IP65, PM12 - IP67

Ordering procedure

PT-25/___/L = ... mm/___/___/___/___ ÷ °C/___

Electrical connection: **PD** (connector DIN EN 175301-803)
PM12 (connector M12x1)

Immersion length: **L=...mm** (standard: 50, 100, 150, 200, 250 mm
other length on request)

Diameter of sensor: **4, 6, 8 mm**

Connection thread: **G1/2"**, other on request

Measuring range

Alarm signal: **23 mA**

Measuring insert: **R** - removable, **NR** - not removable

Rail-mounted smart temperature transmitters type LI-24L



- ✓ Galvanic insulation (In, out)
- ✓ Programmable sensor type
- ✓ Programmable measuring range
- ✓ Thermoresistance line compensation
- ✓ Compensation of thermocouple cold junction
- ✓ Output signal 4...20mA + Hart protocol
- ✓ Ambient temperature from -25 to +75 °C
- ✓ Hart protocol
- ✓ Autodiagnostic system
- ✓ Safety version SIL2/SIL3
- ✓ Intrinsic safe version



I M1 Ex ia I Ma
 II 1G Ex ia IIC T4/T5 Ga

IECEx Ex ia I Ma
 Ex ia IIC T4/T5 Ga

Technical data

Input signal	K, J, S, B, N, T, R, E voltage Pt10, Pt50, Pt100, Pt200, Pt500, Pt1000, Ni100, Cu100, resistance
Limit process	- 10mV < E < 100mV or -100mV < E < 1000mV 0Ω < R < 400Ω or 0Ω < R < 2000Ω
Min. measuring range	10mV or 10Ω
Output signal	4...20mA + HART
Power supply	10...36V DC Safety: 10...30V DC Ex, Safety Ex: 10...30V DC
Max. Wires resistance	500Ω
Alarm signal	21,6mA or 3,75 mA or setting by user
Sensor current	0,25mA
Accuracy	± 0,1%
Time constant	0,2...1s
Additional electronic damping	0...30s
Ambient temperature	-40...+85°C
Dimensions (WxHxD)	12,5mmx99mmx114,5mm

Application and function

The temperature transmitter LI-24L is applicable to converting resistance of temperature or voltage of thermocouple sensor to standard current signal 4-20mA. The transmitters have two separate measuring channels enabling measurement of temperature difference, average, average with redundancy, max or min temperature. Transmitter has compensation of ambient temperature influence and compensation of thermocouple cold junction using internal/external (Pt100) sensor or constant temperature.

Most of parameters such as: sensor type, measuring range, current alarm signal when electric circuit is broken, output characteristic correction, user characteristic (60 points) are programmed using PC with HART/USB converter and Raport 2 configuration software.

For request Aplisens can set temperature transmitter parameters like measuring range, type of sensor. Their values are printed on label. Transmitter for rail mounting (TS-35).

Electrical diagrams

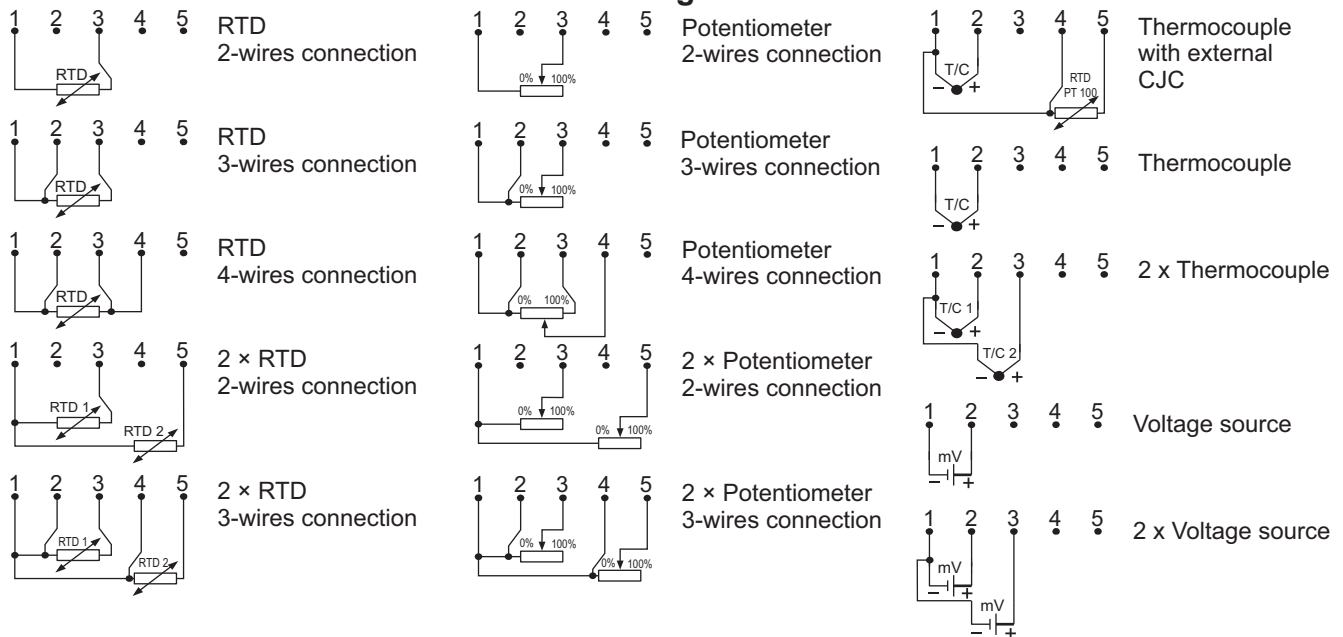

LI-24L/ / / / /

Version: Ex, Safety, none

Alarm signal

Sensor type

Measuring range

Rail-mounted temperature transmitter type ATL

- ✓ Programmable sensor type PT100 i Ni100
- ✓ Programmable measuring range.
- ✓ Thermoresistance line compensation (3 wires line)
- ✓ Output signal 4...20mA
- ✓ Rail- mounting system.



Application and function

The temperature economical transmitter ATL is applicable to converting resistance of temperature sensor to standard current signal 4...20mA.

Most of parameters such as: sensor type, input signal, measuring range may be adapted by user for specific requirements of his measuring system. The transmitter is programmed using PC with RS converter and Aplisens AT configuration software.

If you define type of sensor, measuring range in the order, then the transmitter is programmed with required parameters and their values are printed on serial number label.

Transmitter for rail mounting.

Technical data

Input signal	Pt 100, Ni 100
Limit process	$20\Omega < R < 380\Omega$
Min. measuring range	10 Ω
Output signal	4 – 20 mA
Power supply	6...29V DC
Load resistance	$R_o[k\Omega] < (U_z - 7V)/25mA$
Alarm signal	23mA or 3,8mA
Accuracy for $\Delta R > 20\Omega$	$\pm 0,2\%$
Thermal error	$\pm 0,1\% / 10^\circ C$
Ambient temperature	-25...+80°C
Error due to supply voltage changes	$\pm 0,1\%$

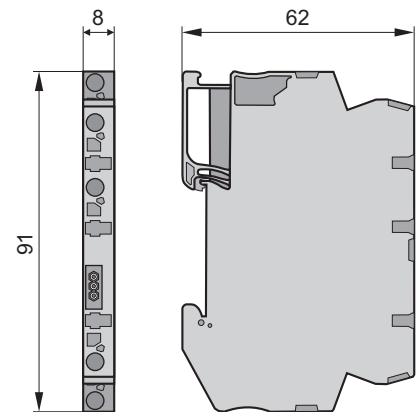

Ordering procedure.

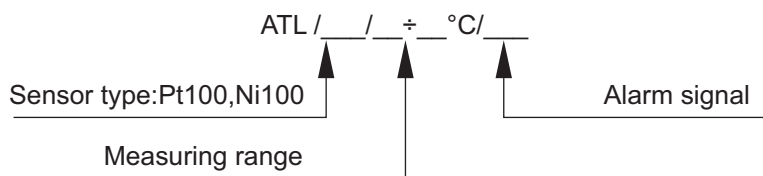

Example: temperature transmitter ATL, sensor type Pt100, measuring range 0...100°C, alarm signal 23mA.

ATL/Pt100/ 0...100°C/23mA

Electrical diagrams

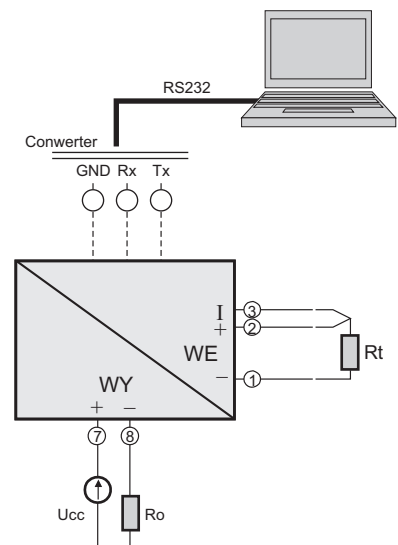

Head-mounted smart temperature transmitter type LI-24G



SIL2/SIL3
Safety version

- ✓ Galvanic insulation (In, out)
- ✓ Programmable sensor type
- ✓ Programmable measuring range
- ✓ Resistant thermoresistance line compensation
- ✓ Compensation of thermocouple cold junction
- ✓ Output signal 4...20mA + Hart protocol
- ✓ Ambient temperature from -25 to +75 °C
- ✓ Hart protocol
- ✓ Safety version SIL2/SIL3
- ✓ Intrinsic Safety version

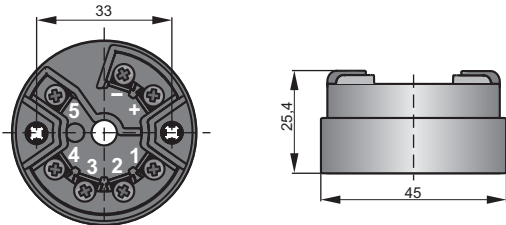

Ex I M1 Ex ia I Ma
II 1G Ex ia IIC T5/T6 Ga
II 1D Ex ia IIIC T105°C Da

IECEX Ex ia I Ma
Ex ia IIC T5/T6 Ga
Ex ia IIIC T105°C Da

Technical data

Input signal	L, K, J, S, B, N, T, R, E voltage Pt10, Pt50, Pt98, Pt100, Pt200, Pt500, Pt1000, Ni100, Cu50, Cu100, resistance
Limit process	- 10mV < E < 100mV or -100mV < E < 1000mV 0Ω < R < 400Ω or 0Ω < R < 2000Ω
Min. measuring range	10mV or 10Ω
Output signal	4...20mA + HART
Power supply	10...36V DC Safety: 10...36V DC Ex, Safety Ex: 10...30V DC
Max. sensor resistance	150Ω/200Ω
Alarm signal	21,6mA or 3,75 mA or setting by user
Sensor current	0,42mA
Accuracy	± 0,1%
Time constant	0,2...1s
Additional electronic damping	0...30s
Ambient temperature	-40...85°C Ex, Safety Ex: -40...70°C

Application and function

The temperature transmitter LI-24G is applicable to converting resistance of temperature or voltage of thermocouple sensor to standard current signal 4-20mA. The transmitter has two separate measuring channels enabling measurement of temperature difference, average, average with redundancy, max or min temperature. Transmitter has compensation of ambient temperature influence and compensation of thermocouple cold junction using internal/external (Pt100) sensor or constant temperature.

Most of parameters such as: sensor type, measuring range, current alarm signal when electric circuit is broken, output characteristic correction, user characteristic (60 points) are programmed using PC with HART/USB converter and Raport 2 configuration software.

For request Aplisens can set temperature transmitter parameters like measuring range, type of sensor. Their values are printed on label.

Electrical diagrams.

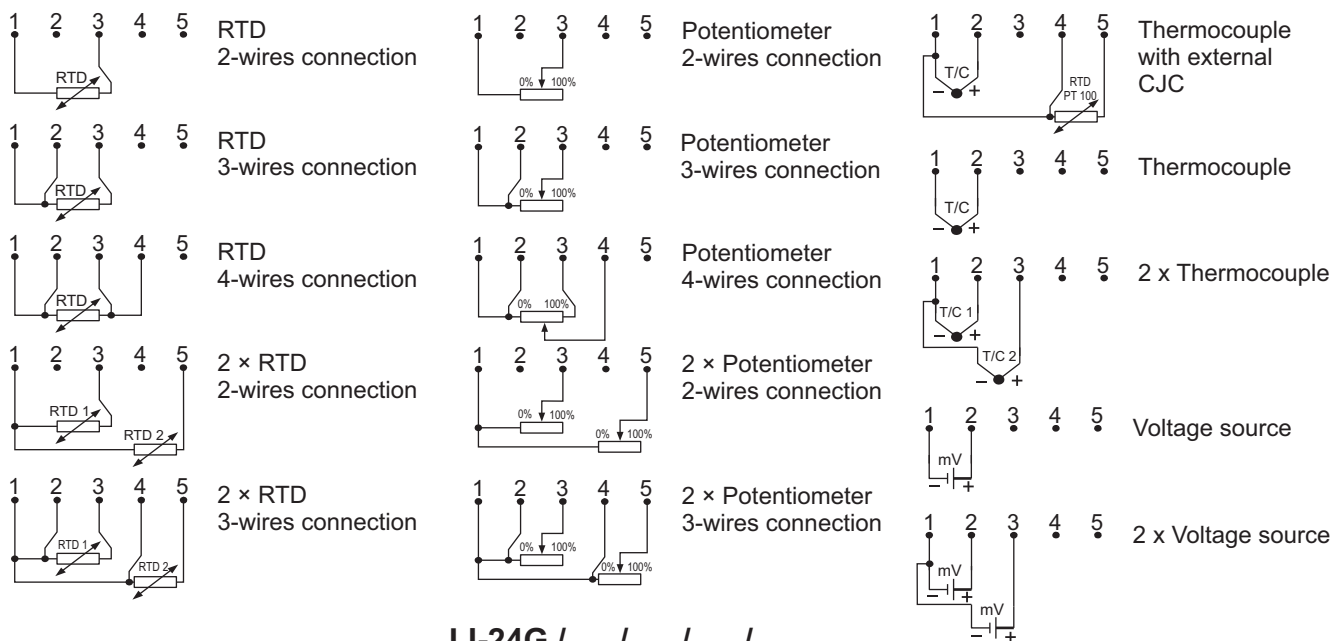

LI-24G / / / /

Version: Safety, Ex, none Alarm signal
Sensor type Measuring range

Head-mounted temperature transmitter AT-2



- ✓ Sensor type Pt100 or Ni100
- ✓ Thermoresistance line compensation (3 wires line)
- ✓ Output signal 4...20mA
- ✓ Head-mounting system.

Application and function

The temperature economical transmitter AT-2 is applicable to converting resistance of temperature sensor to standard current signal 4...20mA. Most of parameters such as: sensor type, input signal, measuring range may be adapted by user for specific requirements of his measuring system.

User define type of sensor, measuring range in the order, the transmitter are programmed with required parameters and their values are printed on serial number label. Transmitter for head mounting.

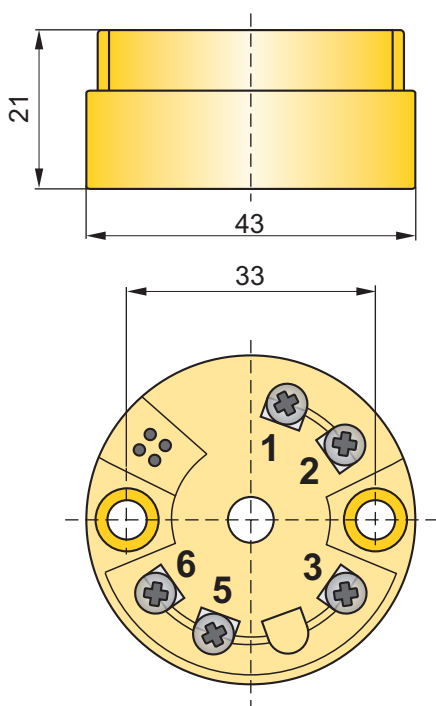

Technical data

Input signal	Pt 100
Limit process	$20\Omega < R < 380\Omega$
Min. measuring range	25°C
Output signal	4 – 20 mA
Power supply	7,5...30V DC
Load resistance	$R_d[k\Omega] < (U_z - 7,5V)/22mA$
Alarm signal	22mA or 3,6mA
Accuracy for $\Delta R > 20\Omega$	$\pm 0,1\%$
Thermal error	$\pm 0,1\% / 10^\circ C$
Ambient temperature	-40...+85°C
Error due to supply voltage changes	$\pm 0,01\%/V$

Note: for spans smaller than 75°C, the only permissible start values are: -40°C, -20°C, 0°C, +20°C and +40°C.

Electrical diagrams

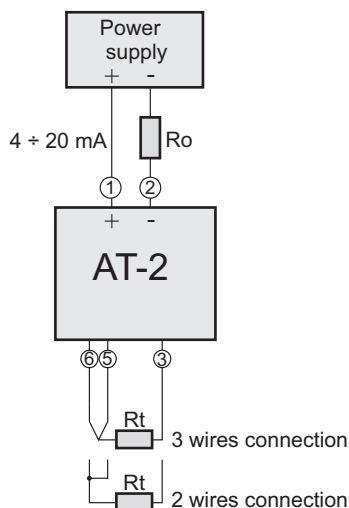

Ordering procedure.

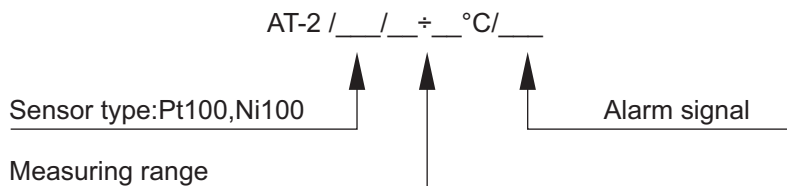

Example: temperature transmitter AT-2, sensor type Pt100, measuring range 0...100°C, alarm signal 22mA.

AT-2/Pt100/ 0...100°C/22mA

Head-mounted temperature transmitter type ATX-2



- ✓ Sensor type: Pt100, Pt500, Pt1000, Ni100
- ✓ Thermoresistance line compensation
- ✓ Output signal 4...20mA
- ✓ ATEX certificate $\text{Ex II 1G Ex ia IIC T6}$
- ✓ Head-mounting system.

Application and function

The temperature transmitters are applicable to converting resistance of temperature sensor to standard current signal 4...20mA. Most of parameters such as: sensor type, input signal, measuring range, may be adapted by user for specific requirements of his measuring system. User define type of sensor, measuring range in the order, the transmitter are programmed with required parameters and their values are printed on serial number label. Transmitter for head mounting.

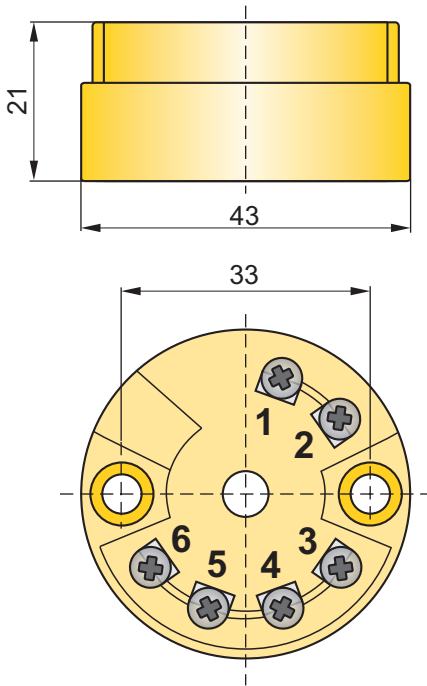

Technical data

Input signal	Pt,Ni
Min.measuring range	10°C
Output signal	4-20mA
Power supply	8...30VDC
Load resistance	$R_d[k\Omega] < (U_z - 8V) / 22mA$
Alarm signal	21mA or 3,5mA
Accuracy for $\Delta R > 20\Omega$	$\pm 0,2\%$
Thermal error	$\pm 0,05\% / 10^\circ C$
Ambient temperature	-40...+85°C
Accuracy:	

PT100: -100÷200°C	±0,2°C	PT1000: -100÷200°C	±0,2°C
PT100: -200÷850°C	±0,4°C	PT1000: -100÷250°C	±0,4°C
PT500: -100÷200°C	±0,2°C	Ni100: -60÷250°C	±0,2°C

Electrical diagrams

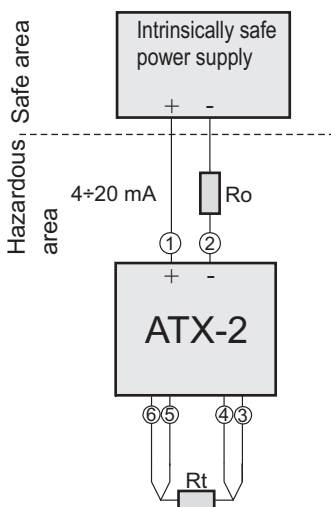

Input parameters

Input terminals 3, 4, 5, 6:
 $U_o = 9,6V$, $I_o = 4,5mA$, $P_o = 11mW$,
 $L_o = 4,5mH$ dla IIC; 8,5mH dla IIB
 $C_o = 709nF$ dla IIC; 1300nF dla IIB

Supply terminals 1(+) 2(-):
 $U_i = 30V$, $I_i = 100mA$, $P_i = 750mW$, $L_i \sim 0$, $C_i \sim 0$

Ordering procedure

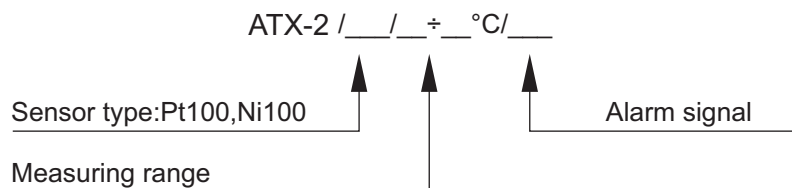

Example: temperature transmitter ATX-2, sensor type Pt100, measuring range 0...100°C, alarm signal 23mA.

ATX-2/Pt100/0...100°C/23mA

Head-mounted temperature transmitter type GI-22-2, GIX-22-2



- ✓ Galvanic insulation (In, out)
- ✓ Thermoresistance line compensation (3 and 4 wires line)
- ✓ Compensation of thermocouple cold junction
- ✓ Output signal 4...20mA
- ✓ Head-mounting system
- ✓ Certificate ATEX II 1G Ex ia IIC T6 (GIX-22-2 version).

Application and function

The temperature transmitters are applicable to converting resistance of temperature or voltage of thermocouple sensor to standard current signal 4...20mA.

Most of parameters such as: sensor type, input signal, measuring range, may be adapted by user for specific requirements of his measuring system.

User define type of sensor, measuring range in the order, the transmitter are programmed with required parameters and their values are printed on serial number label.

Transmitter for head mounting.

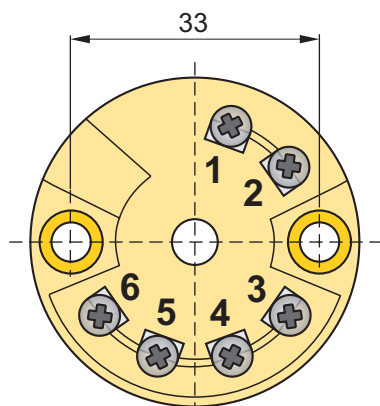
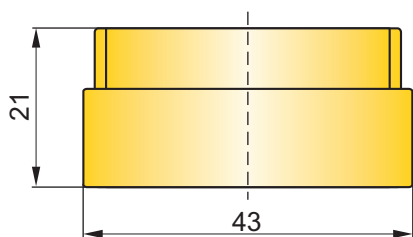

Electrical diagrams

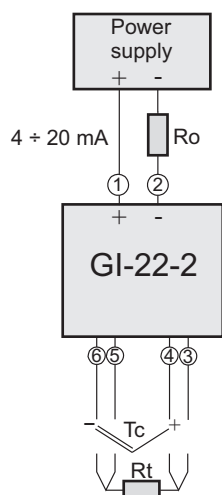

Technical data

Input signal	J, L, U, T, E, K, N, S, R, B, Pt, Ni
Min. measuring range	10°C for Pt, Ni 50°C for J, L, U, T, E, K, N 500°C for S, R, B
Output signal	4 – 20mA
Power supply	8...35V DC 8-30V DC for GIX-22-2
Load resistance	$R_0[k\Omega] < (U_z - 11V)/25mA$
Alarm signal	22mA or 3,6 mA
Galvanic insulation	Optoelectrical
Accuracy	

PT100: -100÷200°C	±0,2°C	J: -210÷1200°C	±0,5°C over -150°C
PT100: -200÷850°C	±0,4°C	L: -200÷900°C	±0,5°C
PT500: -100÷200°C	±0,2°C	U: -200÷600°C	±0,5°C
PT100: -200÷250°C	±0,4°C	T: -270÷400°C	±0,5°C over -200°C
PT1000: -100÷200°C	±0,2°C	E: -270÷1000°C	±0,5°C over -150°C
PT1000: -100÷250°C	±0,4°C	K: -270÷1372°C	±0,5°C over -140°C
Ni100: -60÷250°C	±0,2°C	N: -270÷1300°C	±1°C over -100°C
		S: -50÷1768°C	±2°C over +20°C
		R: -50÷1768°C	±2°C over +50°C
		B: 0÷1820°C	±2°C over +400°C

Thermal error	±0,05 %/10°C
Voltage error	±0,01%/V
Ambient temperature	-40...+85°C

Ordering procedure

GIX-22-2 / ___ / ___ ÷ °C / ___
GI-22-2 / ___ / ___ ÷ °C / ___

Sensor type

Measuring range

alarm signal:
22mA or 3,6mA

Chapter X

Temperature sensors

Temperature sensor CT 25.....	X/ 2
Temperature sensors with integrated protection tube or additional thermowell	X/ 3
Temperature sensor for high temperature applications	X/ 8
Temperature sensors without additional protection tube CT X.....	X/ 10
Cable temperature sensor CT GE1, CT E1, CT R6, CT E2.....	X/ 12
Measuring insert, clamping grips.....	X/ 13
Thermowells.....	X/ 14

NEW

Temperature sensor type CT-25

- ✓ RTD output signal
- ✓ Stainless steel casing and wetted parts

Application and construction

Temperature sensor type CT-25 is designed for temperature measurement of liquid and gaseous media in range from -40 to +100°C. Casing of sensor and wetted parts are made in stainless steel. Available electrical connections are angular connector DIN EN 175301-803 or connector M12x1.

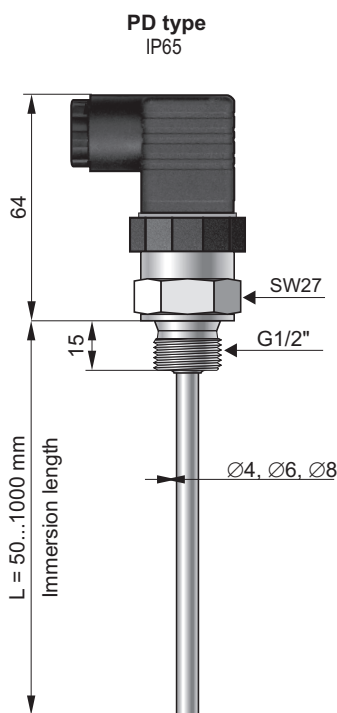

Technical data

Measuring range	-40...100°C
Accuracy	±(0,3+0,005 t)°C (class B per IEC 60751)
Wetted parts material	316
Sensor diameter	Ø4, Ø6, Ø8mm
Process connection	G1/2", other on request
Immersion length	50...1000mm
Extension neck	on request
Ingress protection	PD - IP65, PM12 - IP67

Ordering procedure

CT-25/___/L = ... mm/___/___/___/___

- Electrical connection: **PD** (connector DIN EN 175301-803)
PM12 (connector M12x1)
- Immersion length: **L=...mm** (standard: 50, 100, 150, 200, 250 mm
other length on request)
- Diameter of sensor: **4, 6, 8 mm**
- Connection thread: **G1/2"**, other on request
- Measuring element: **Pt100**
- Number of wires: **2, 3, 2x2** (only in PM12 version)

TEMPERATURE SENSORS WITH INTEGRATED PROTECTION TUBE OR ADDITIONAL THERMOWELL TYPE CT

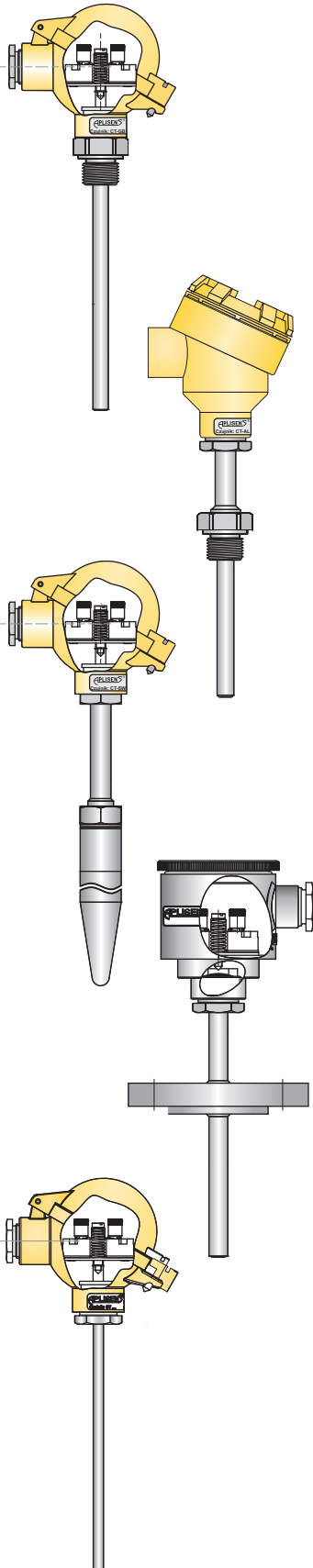

- ✓ RTD (Pt100, Pt1000) and TC sensors
- ✓ ATEX Exia certificate
- ✓ ATEX Exd certificate
- ✓ DNV/GL marine certificate

Features

Temperature sensors CT are offered as Pt100/Pt1000 resistance thermometers or thermocouples.

In resistance sensors (RTD) platinum resistors change their electrical resistance as a function of temperature. RTD, the most commonly used sensors in industry, are suitable for applications between $-196...+600^{\circ}\text{C}$. The accuracy classes A and B are available with a tolerance acc. to IEC60751.

Thermocouples are made of two different conductors joined at the end. The temperature difference between junction, placed in measuring point (hot junction), and wire ends (cold junction), generate voltage proportional to the difference of temperature between these junctions. Thermocouples are suitable for the measurement of high temperatures, up to 1700°C .

The accuracy classes 1 and 2 are available with tolerance acc. to IEC60584.

Description

Temperature sensors model CT are offered in two designs:

- with integrated protection tube, fully welded and screwed into enclosure.
- for additional thermowell: machined from bar stock or from pipe.

In both cases sensors are equipped in spring-loaded measuring inserts which are replaceable. The interchangeable inserts can be replaced without dismantling sensor from installation. This enables inspection or, if necessary, service without stopping of running production process.

Sensors are suitable for gases and liquids. A large number of approvals and wide choice of process connections, connection heads, lengths of immersion and necks, types of measuring elements and materials of wetted parts allow for applications in:

- power industry
- chemical and petrochemical industry
- marine and offshore industry
- heavy industry
- food industry
- machine building
- plant construction

Technical details

Process part type	Measuring range
GB1	Pt100: -70...150°C Marine version: -25...150°C
GN1	Pt100: -70...500°C / -196...150°C 1) TC type J/K: -40...550°C Marine version: -25...500°C
T1	Pt100: -70...500°C / -196...150°C 1) TC type J/K: -40...550°C Marine version: -25...500°C
P1	Pt100: -70...500°C / -196...150°C 1) TC type J/K: -40...550°C Marine version: -25...500°C
GB1X + thermowell	Pt100: -70...150°C Marine version: -25...150°C
GN1X + thermowell	Pt100: -70...500°C TC type J/K: -40...570°C Marine version: -25...500°C

1) On request

Accuracy		
For resistance thermoelements Pt100 acc. to PN-EN 60751:2009		
Class	Temperature range (°C)	Accuracy (°C)
A	-30...300	$\pm(0,15+0,002 \cdot t)$
B	-50...500	$\pm(0,3+0,005 \cdot t)$
For resistance thermocouples K acc. to PN-EN 60584-1:2014		
Class	Temperature range (°C)	Accuracy (°C)
1	-40...375	$\pm 1,5$
	375...1000	$\pm 0,004 \cdot t $
2	-40...333	$\pm 2,5$
	333...1200	$\pm 0,0075 \cdot t $
For resistance thermocouples J acc. to PN-EN 60584-1:2014		
Class	Temperature range (°C)	Accuracy (°C)
1	-40...375	$\pm 1,5$
	375...700	$\pm 0,004 \cdot t $
2	-40...333	$\pm 2,5$
	333...750	$\pm 0,0075 \cdot t $

Certification						
Exia		II 1/2 G Ex ia IIC T6...T1 Ga/Gb II 1D Ex ia IIIC T75°C Da			I M1 Ex ia I Ma	1)
Exd 2)		II 2G Ex d IIB+H ₂ T** Gb II 2D Ex tb IIIC T* Db	3)		II 1/2G Ex d IIB+H ₂ T** Ga/Gb II 1/2D Ex tb IIIC T* Da/Db	4)
MR	Marine certificate DNV					

1) Only CT-CL version

2) Only CT-AL version

3) Location of complete equipment in zone 1 or 21

4) Measuring stem with screwed to the opening D2 of housing thermowell, with proper wall thickness (zone 0 or 20):

a) minimum 1,5mm, made of corrosion resistant steel or

b) minimum 1mm and fixed in protective thermowell (wall thickness minimum 1mm) made of corrosion resistant steel

Casing

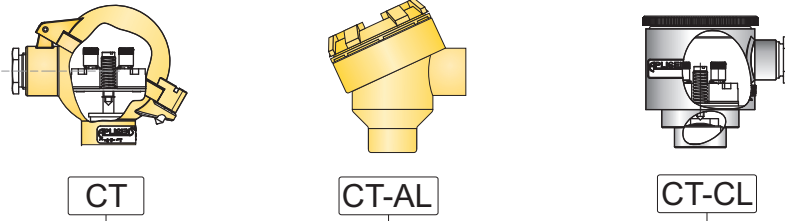

Process part

with integrated protection tube

for additional thermowell

GB1

GN1

T1

P1

GB1X

GN1X

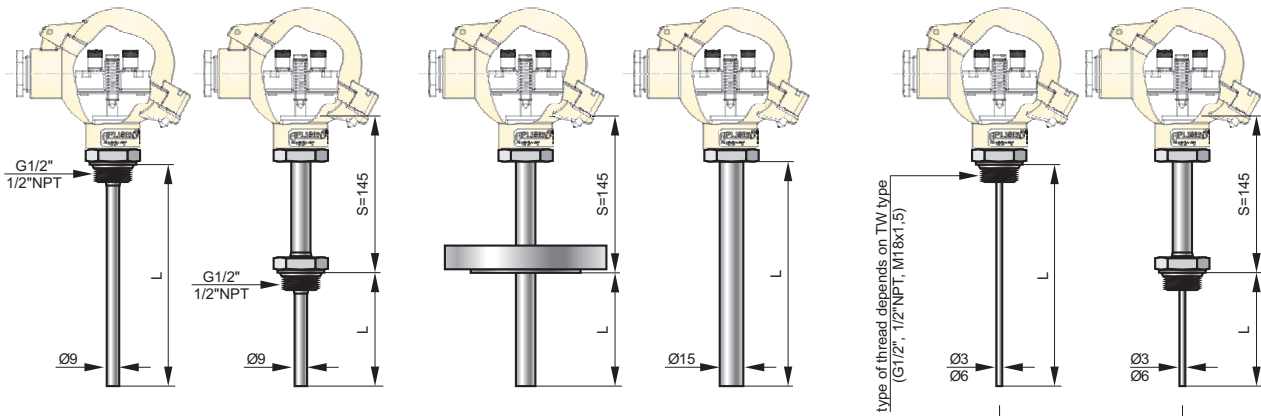

thermowell

OG2.

OG3.

T

SW2

SW2T

SWG

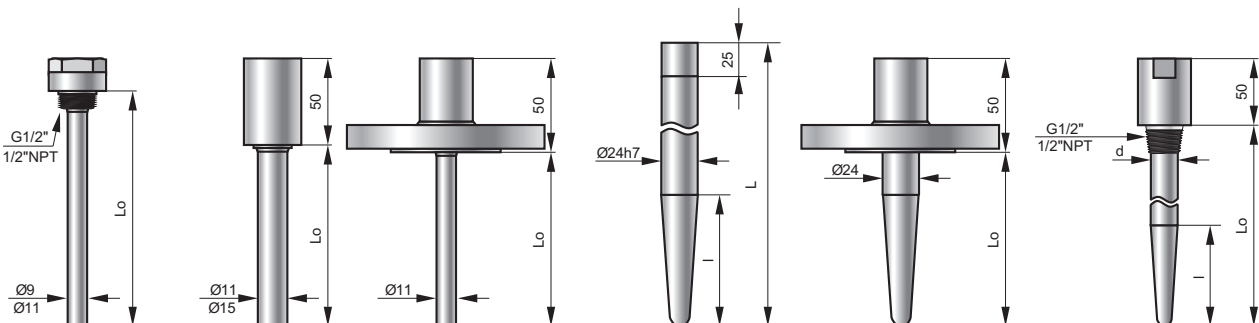

ORDERING PROCEDURE

Head Material		
CT		aluminum housing NA type
CT-AL		aluminum housing DAO type
CT-CL		stainless steel housing KO type
Process part		
sensors with integrated protection tube		
GB1		sensor with threaded process connection, diameter of sensor 9mm, 316ss
GN1		sensor with threaded process connection, diameter of sensor 9mm, neck S=145mm, wetted parts 316ss
T1		diameter of sensor 11mm, neck S=145mm, wetted parts 316ss
P1		diameter of sensor 15mm, wetted parts 316ss
sensors for additional thermowell		
GB1X		spring loaded sensor with threaded process connection, wetted parts 316ss
GN1X		spring loaded sensor with threaded process connection, neck S=145mm, wetted parts 316ss
Certificate		
x		standard version, no certificates
Exia /II		II 1/2 G Ex ia IIC T6...T1 Ga/Gb II 1D Ex ia IIIC T75°C Da
Exia /I		I M1 Ex ia I Ma
Exd		II 2G Ex d IIB+H ₂ T** Gb II 2D Ex tb IIIC T* Db
		II 1/2G Ex d IIB+H ₂ T** Ga/Gb II 1/2D Ex tb IIIC T* Da/Db
MR		marine certificate
Measuring element		
Pt		Pt100
2xPt		2xPt100
Pt1000		Pt1000
J		TC type J
2xJ		2x TC type J
K		TC type K
2xK		2xTC type K
Class of element		
A/3		TR sensor, Class A, 3 wires
A/4		TR sensor, Class A, 4 wires
B/2		TR sensor, Class B, 2 wires
1/O		TC sensor, Class 1, ungrounded junction
2/O		TC sensor, Class 2, ungrounded junction
Thermowell		
x		no thermowell
OG2.9		welded type, ext. diameter 9mm, wetted parts mat. 316ss
OG2.11		welded type, ext. diameter 11mm, wetted parts mat. 316ss
OG2.15		welded type, ext. diameter 15mm, wetted parts mat. 316ss
OG3.11		welded type, ext. diameter 11mm, wetted parts mat. 316ss
OG3.15		welded type, ext. diameter 15mm, wetted parts mat. 316ss
OGT1.11		welded type, ext. diameter 11mm, wetted parts mat. 316ss
OGT1.15		welded type, ext. diameter 15mm, wetted parts mat. 316ss
SWG		drilled type, ext. diameter 17mm, wetted parts mat. 316ss
SW2		drilled type, ext. diameter 24h7, wetted parts mat. 316ss,
SW2T		drilled type, ext. diameter 24mm, wetted parts mat. 316ss,
Process connection		
threaded type		
M20x1,5		thread M20x1,5
G1/2		thread G1/2"
1/2NPT		Thread 1/2"NPT
flange type		
DN25PN40		flange DN25PN40
DN40PN40		flange DN40PN40
DN50PN40		flange DN50PN40
ANSI 1" #150		flange ANSI 1" #150
ANSI 1,5" #150		flange ANSI 1,5" #150
ANSI 2" #150		flange ANSI 2" #150
Clamping grips		
UG15		diameter 15mm, thread M24x2
Length of immersion part L		
L=		required length of immersion [mm]

Equipment of housing		
KZ		terminal block
TR		wires connections for assembling of temperature transmitter
AT-2		transmitter 4...20mA model AT-2
ATX-2		ATEX transmitter 4...20mA model ATX-2
LI-24G		smart transmitter 4...20mA + HART model LI-24G
LI-24G/Ex		ATEX smart transmitter 4...20mA + HART model LI-24G/Ex
LI-24G/SIL2		SIL 2, smart transmitter 4...20mA + HART model LI-24G/SIL2
LI-24G/Ex/SIL2		SIL 2, ATEX smart transmitter 4...20mA + HART model LI-24G/Ex/SIL2
GI-22-2		transmitter 4...20mA model GI-22-2
GIX-22-2		ATEX transmitter 4...20mA model GIX-22-2
	Measuring range	
	...	set range [deg C]
	Alarm signal	
	HI	signal >20mA
	LO	signal <4mA
	Special version	
	ND=...	diameter of sensor or thermowell different than standard [mm]
	NE=...	length of neck different than 145mm [mm]
	NM.....	wetted parts material different than standard
	NPC...	process connection different than standard
	...	description of required parameters

Temperature sensor for high temperature applications

- ✓ - TC sensors J, K, S, B
- ✓ - ATEX Exia certificate

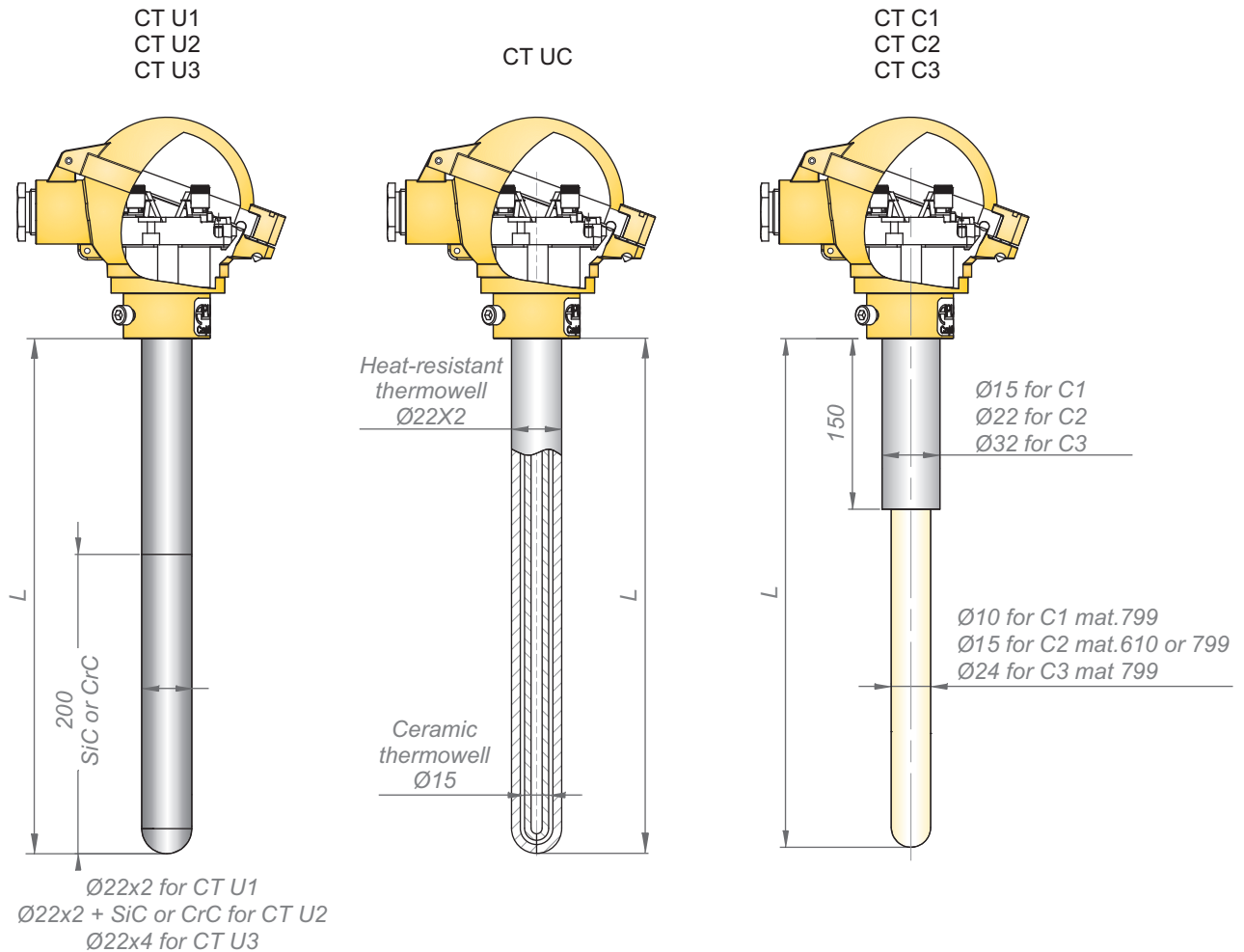

Features

Temperature sensors CT C, CT U, are offered as thermocouples.

Thermocouples are made of two different conductors joined at the end. The temperature difference between junction, placed in measuring point (hot junction), and wire ends (cold junction), generate voltage proportional to the difference of temperature between these junctions. Thermocouples are suitable for the measurement of high temperatures, up to 1700°C.

The accuracy classes 1 and 2 are available with tolerance acc. to IEC60584

Description

Temperature sensors model CTC and CTU are designed for high temperatures up to 1700°C. Various wetted parts materials like heat resistant stainless steel, ceramic or sialon allow to cover many high temperature applications.

Sensors are offered with various fitting elements.

Typical application are:

- chemical application,
- metal alloys industry

Ordering procedure			
CT			
Process part			
	U1		
	U2		
	U3		
	C1		
	C2		
	C3		
Certificate			
	x		standard version, no certificates
	Exia /II		 II 1/2 G Ex ia IIC T6...T1 Ga/Gb II 1D Ex ia IIIC T75°C Da
Measuring element			
	J		TC type J
	2xJ		2x TC type J
	K		TC type K
	2xK		2xTC type K
	S		TC type S
	2xS		2xTC type S
	B		TC type B
	2xB		2xTC type B
Class of element			
	1/O		TC sensor, Class 1, ungrounded junction
	2/O		TC sensor, Class 2, ungrounded junction
Length			
	L=		required length of immersion [mm]
	S, L1, L2...=...		required length of immersion end extension [mm] – only CT-F
Process connection			
	X		Without clamping grip
	UC1-22		
	UC2-22		

TEMPERATURE SENSORS WITHOUT ADDITIONAL PROTECTION TUBE TYPE CT X

- ✓ RTD (Pt100, Pt1000) and TC sensors
- ✓ ATEX Exia certificate

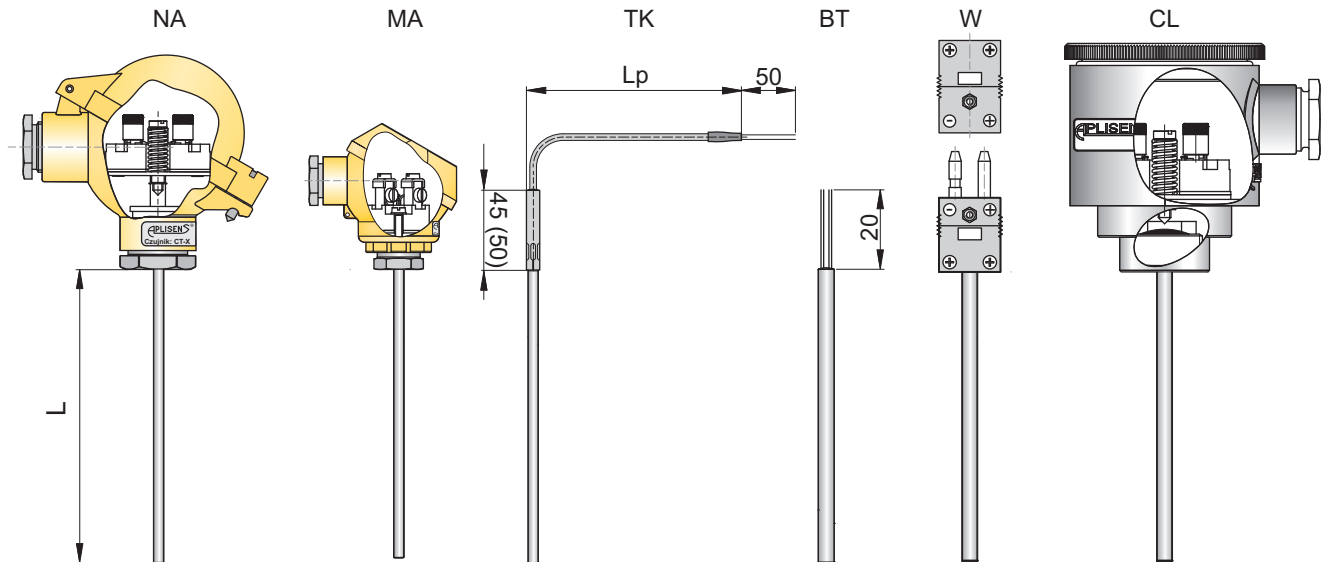

Features

Temperature sensors CT X are offered as Pt100/Pt1000 resistance thermometers or thermocouples.

In resistance sensors (RTD) platinum resistors change their electrical resistance as a function of temperature. RTD, the most commonly used sensors in industry, are suitable for applications between $-200...+600^{\circ}\text{C}$. The accuracy classes A and B are available with a tolerance acc. to IEC60751.

Thermocouples are made of two different conductors joined at the end. The temperature difference between junction, placed in measuring point (hot junction), and wire ends (cold junction), generate voltage proportional to the difference of temperature between these junctions.

The accuracy classes 1 and 2 are available with tolerance acc. to IEC60584.

Description



Temperature sensors model CT X are offered without additional protection tube.

Small diameters and flexibility of process part allow for assembling in not easily accessible places.

Sensors are suitable only for non-aggressive or abrasive liquids and gases. Usually are mounted directly into the process. Sensors can be mounted also into thermowells, in this case is recommended assembling with spring-loaded fitting or using transmission liquid.

Sensors are offered with various screwed connections of for insertion, with fitting elements like union nuts. Typical application are:

- machine building
- temperature measurement in motors, bearings

Ordering procedure			
CTX			
Diameter of sensor			
3		3mm	
6		6mm	
8		8mm	
Certificate			
x		standard version, no certificates	
Exia /II		 II 1/2 G Ex ia IIC T6...T1 Ga/Gb  II 1D Ex ia IIIC T75°C Da	
Exia /I		 I M1 Ex ia I Ma	available with KO housing only
Measuring element			
Pt		Pt100	
2xPt		2xPt100	
J		TC type J	
2xJ		2x TC type J	
K		TC type K	
2xK		2xTC type K	
Class of element			
A/3		TR sensor, Class A, 3 wires	
A/4		TR sensor, Class A, 4 wires	
B/2		TR sensor, Class B, 2 wires	
1/O		TC sensor, Class 1, ungrounded junction	
2/O		TC sensor, Class 2, ungrounded junction	
Length			
L=		required length of immersion [mm]	
Process connection			
X		Without threaded connection	
UG/G1/2"		clamping grips with thread G1/2"	
UG/1/2"NPT		clamping grips with thread 1/2"NPT	
UG/G1/4"		clamping grips with thread 1/4"NPT	
Electrical connection			
BT			
TK			
W			
MA			
KO			
NA			

Measuring insert W2, W4, W5

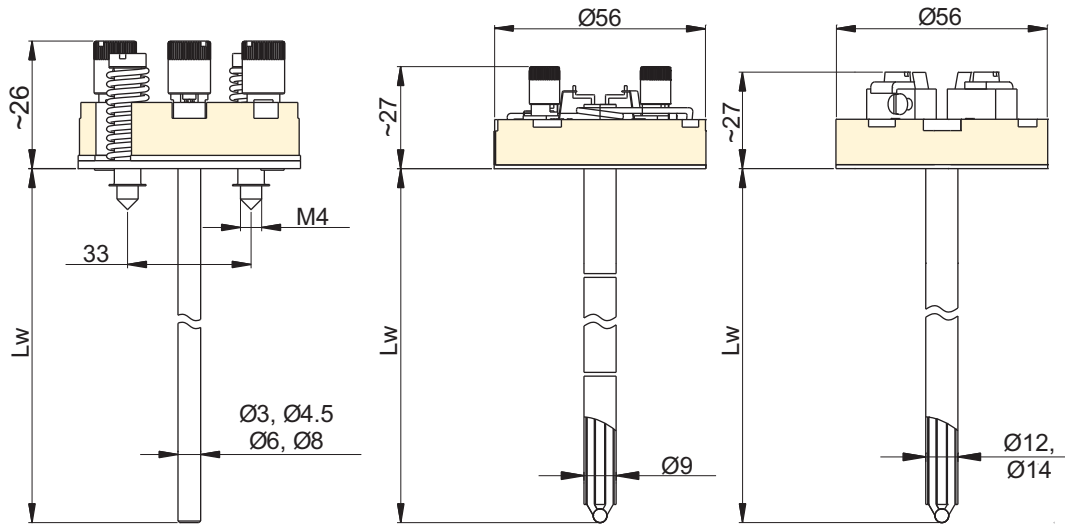

Measuring range of insert

Ordering procedure

with example of ordering code:

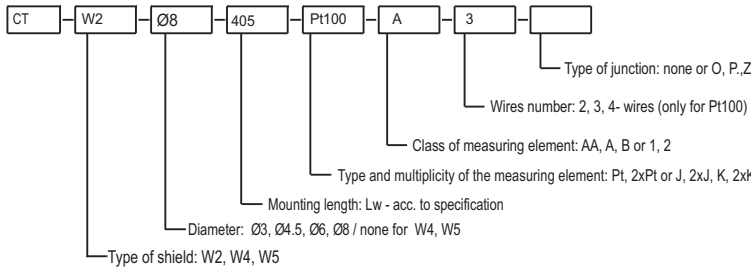

	Insert type		
	W2	W4	W5
Pt	-70÷500°C/-196÷150°C**		
J	-40÷550°C		
K	-40÷550°C/-40÷1000°C	-40÷1000°C (1100°C)*	-40÷1000°C (1150°C)*
S		0÷1300°C (1600°C)*	
B		600÷1600°C (1800°C)*	
Shield	316/Inconel	Ceramic	Ceramic

* - value in the bracket is the maximum admissible momentary temperature
 ** - low temperature version

CLAMPING GRIPS APPLIED FOR MOUNTING THE TEMPERATURE SENSORS

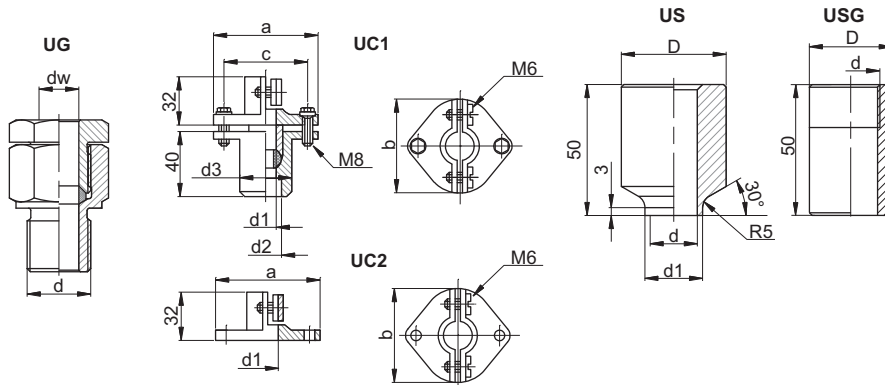

Type	Marking	Eksternal diameter of sensor's shield [mm]	Dimensions [mm]													Material
			dw	s	l	d	k	a	b	c	d1	d2	d3	D		
UG	UG6	6	6.5	22	16	M16x1.5	28									316ss
	UG8	8	8.5	22	16	M16x1.5	28									
	UG15	15	15.5	32	20	M24x2	32									
UC1	UC1-15	15						75	50	55	16	26	35		St30	
	UC1-22	22						90	65	70	23	33	40			
UC2	UC2-15	15						75	50	55	16			St30		
	UC2-22	22						90	65	70	23					
US	US18					Ø18H7					22			40	316ss 15HM 10H2M	
	US24					Ø24H7					30			50		
USG	USG-M20x1.5 USG-G1/2" USG-1/2"NPT					M20x1.5 G1/2" 1/2"NPT								30	316ss 15HM	

Admissible load: UG - 8MPa, UC1 - 0,1MPa

Ordering procedure with example of ordering code:

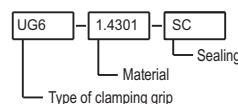

Welded thermowells

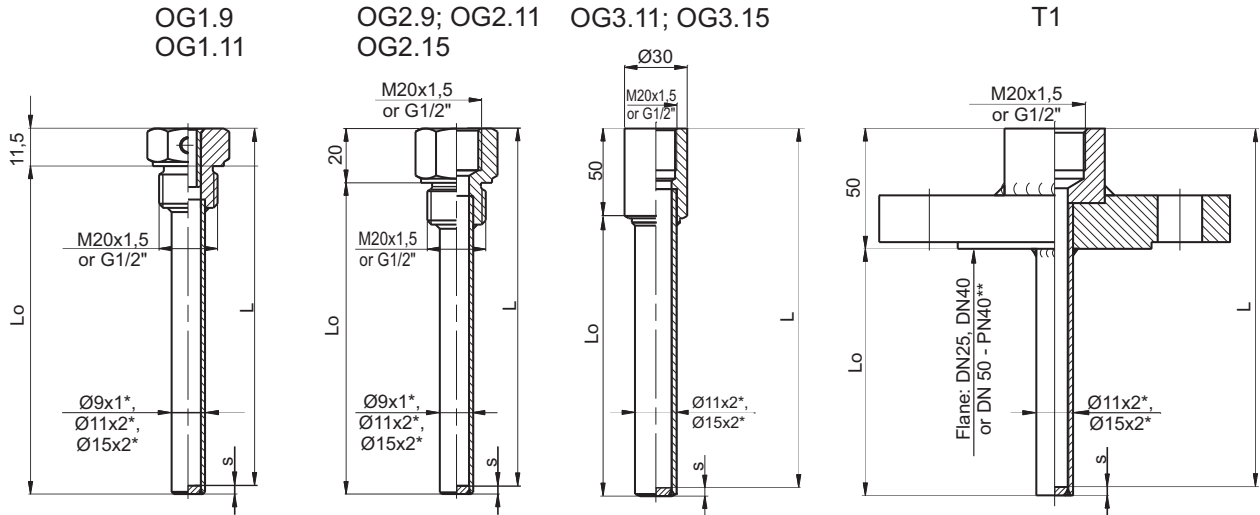

*Standard material: steel 316
s- depends on TW diameter

Drilled thermowells

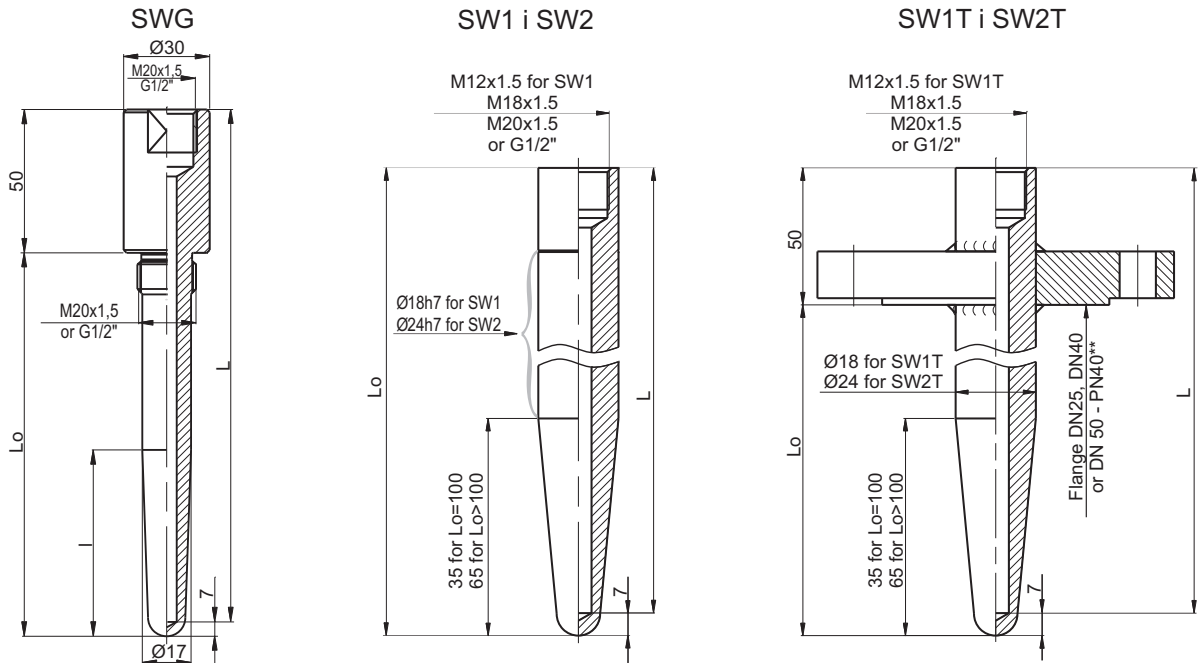

Standard material: steel 316, 1.7335 (13CrMo4-5, 15HM), 1.7380 (10CrMo9-10, 10H2M)

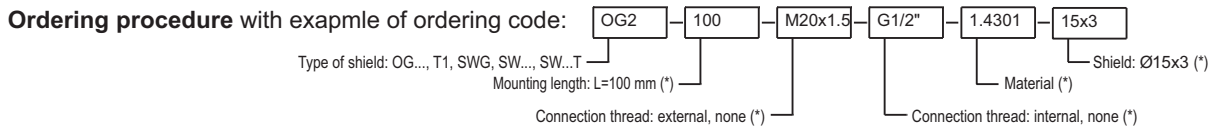

ADMISSIBLE LOADS FOR PARTICULAR TYPES OF SHIELDS AT SPECIFIED WORKING CONDITIONS

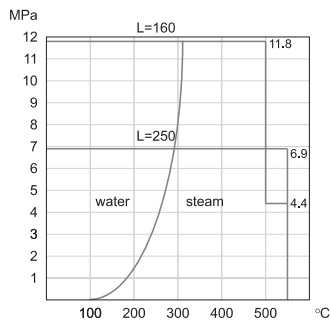

Graph 1. Admissible load of the G1 and T1 shields at the conditions of work - 15HM, 1H18N9T, H17N13M2T

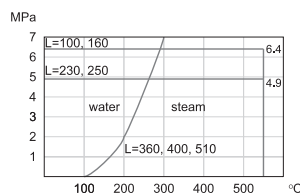

Graph 2. Admissible load of the GN1 and GB1 shields at the conditions of work - 15HM, 1H18N9T, H17N13M2T

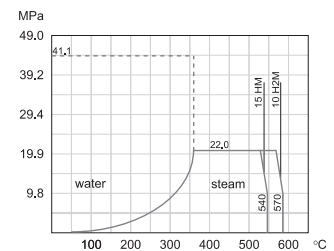

Graph 3. Admissible load of the SW1 and SW2 shields at the conditions of work

Notes

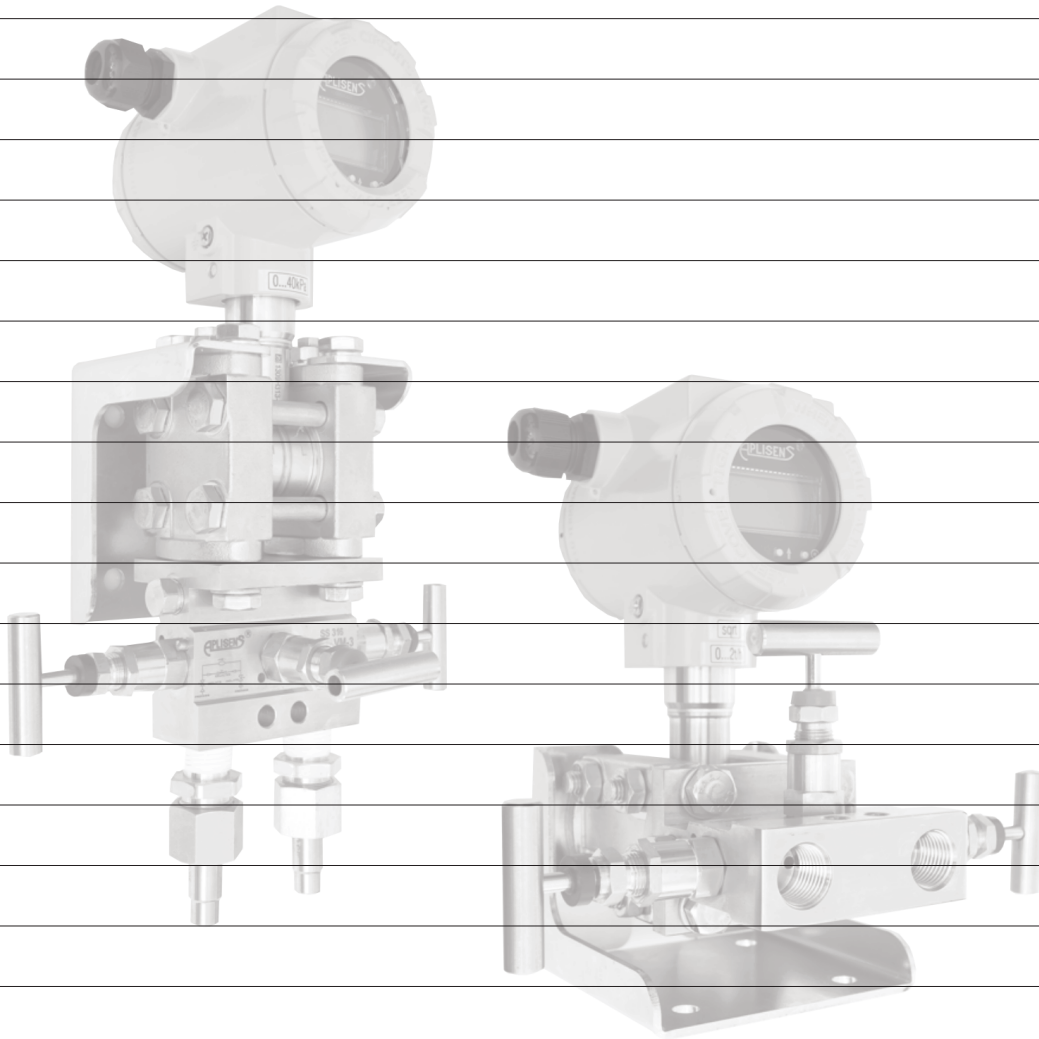

Chapter XI

Electropneumatic positioner

Electropneumatic positioner APIS..... XI/ 2

Electropneumatic positioner APIS

- ✓ HART protocol
- ✓ ATEX certificate  II 2G Exia IIC T5/T6 Gb
- ✓ Simple in installation and programming
- ✓ Possibility of remote assembling of positioner
- ✓ Low air consumption
- ✓ Programmable speed of movement of the actuator's piston rod
- ✓ Position transmitter
- ✓ Possibility of manual controlling of position of actuator's piston rod

*one device for
linear and rotational
actuators*



Technical data

Input signal (control)	4...20mA + Hart
Output signal (position transmitter)	4...20mA
Supply of position transmitter	10÷36 VDC (Ex 10÷30 VDC)
Supply pressure	140÷800 kPa
Pneumatic input signal (control actuator)	0...100% of supply pressure
Own air consumption	≤ 0,035 kg/h at supply voltage 140 kPa ≤ 0,015 kg/h at supply voltage 600 kPa ≥ 3,25 kg/h at supply voltage 140 kPa ≥ 13kg/h at supply voltage 800 kPa
Air mass stream on positioner output	≥ 3,25 kg/h at supply voltage 140 kPa ≥ 13kg/h at supply voltage 800 kPa
Actuator piston rod displacement range	10÷100 mm (for single-acting linear actuators) 80÷900 mm (for double-acting linear actuators) 0÷180° (for rotational actuators)
Actuator operation characteristics	linear
Positioner operation mode	normal or reversible
Positioner transducer mode	normal or reversible
Additional errors	< 0,05% / 100kPa
- from supply pressure changes	0,15% / 10°C – for temperature range -30°C÷+60°C
- from ambient temperature changes	0,25% / 10°C – for temperature range -40°C÷-30°C and +60°C÷+85°C
- from vibration in range:	
10...60Hz, amplitude < 0,35 mm	0,25%
60...500Hz, acceleration 5g	< 0,4%
Hysteresis	< 0,1%
Insensibility threshold	< 0,1%
Protection degree of positioner enclosure	IP 65 according to PN-EN 60529:2003
Operation position	any
Weight	1,8 kg

Operating conditions

Working medium	air free of dust, oil, aggressive pollutants, solid particles bigger than 1.5 µm, such relative humidity not lower that dew point's temperature should not be lower than 10°C with respect to ambient temperature (acc. to PN-EN 60654-2:1999).
Ambient temperature	
Execution without manometers and with stainless steel manometers:	-40°C÷+85°C
Executions with manometers in stainless steel	
Humidity of ambient air	< 95%
Allowable vibrations	acc. to PN-EN 60654-3: 1997; class VH6
10...60Hz,	amplitude < 0,35 mm
60...500Hz	acceleration ≤ 5g

Ordering procedure

APIS - X X X - DXX - RXX - IHE - TXX - PX - MX - WX - AX

Intend use:

- for single-operating actuator..... 1
- for double-operating actuator..... 2

- for installation on actuator..... 0
- for installation outside actuator with
 - external position transmitter (potentiometer) – IP54 ¹⁾... 1
 - external position transmitter (potentiometer) – IP67 ¹⁾... 2
 - external position transmitter (magnetic) – IP67 ¹⁾, ²⁾... 3
 - external position transmitter (potentiometer) – IP65 ³⁾... 4

Distance of positioner from actuator:

- ... m (0 ÷ 15 m)..... XX

Execution:

- standard..... St
- intrinsically safe II 2G Exia IIC T6/T5 Gb..... EX

Analog position transmitter:

- without position transmitter..... 00
- with output signal 4+20 mA ⁴⁾..... 20

Pneumatic connectors:

- without connectors (thread Rp1/8")..... 0
- connectors to brass pipes Ø6 mm..... 1
- connectors to stainless steel pipes Ø6 mm..... 2
- connectors to Polyethylene pipes Ø6 mm..... 3
- connectors to brass pipes Ø8 mm..... 4
- connectors to stainless steel pipes Ø8 mm..... 5
- connectors to Polyethylene pipes Ø8 mm..... 6
- connectors to Polyethylene pipes Ø6 mm (ERMETO).... 7
- other..... 8

Manometers:

- with manometers in st. steel execution
(Ø40 mm, st. steel housing, glass window)..... 2
- with manometers in st. steel execution and st. steel
wetted parts (Ø40 mm, glass window)..... 3
- other..... 4

Electrical entry:

- plastic packing gland (Ø4 ÷ 9 mm cable)..... 1
- nickeled brass packing gland (Ø4 ÷ 9 mm cable)..... 2
- other..... 3

Mounting kit:

- without mounting kit..... 0
- with mounting kit (code according to below table)..... 1

¹⁾ For double-operating linear actuator.

²⁾ Not available with ATEX

³⁾ For single-operating linear diaphragm actuators and single and double-operating rotational actuators

⁴⁾ The positioner can set reverse of analogue output signal (20...4 mA). The reverse function of the output signal is switched on programmatically by the user.

Mounting kit		Type of actuator
APIS-A000	For APIS-100-...	Type P or R, Polna S.A. (mounted on the columns)
APIS-A001		Type 37 or 38, Polna S.A. (yoke)
APIS-A002		Type P1 or R1, Polna S.A. (diaphragm multi-spring)
APIS-A003		Actuator acc. PN-EN 60534-6-1:2001 (Samson, Arca Regler)
APIS-A050	For APIS-X00-...	Actuator acc. EN ISO 5211, DIN 3337, VDI/VDE 38450 Namur, (Air Torque, Ebro-Armaturen, EI-O-Matic)
APIS-AXXX	For APIS-201-...	Actuator acc. ISO 6431 (CNOMO Prema Kielce)
	-SS	Material: stainless steel
	-SO	Material: zinced steel

Chapter XII

Hart communication tools

KAP-03, Raport 2, HART/USB converter XII/ 2

Communication tools

Report 2 software

RAPORT 2 is a software designed for communication and data transfer from transmitters with Hart or Modbus protocol made by APLISENS.

The communication with the transmitters enables:

- Identification of a transmitter,
- Configuration of its output parameters:
- Reading of a PV values (e.g. pressure, output current, degree of output setting in %).
- Enforcement of output current with a given value,
- Transmitter calibration in relation to master pressure,
- Function linearization (user characteristic creator),
- Zeroing

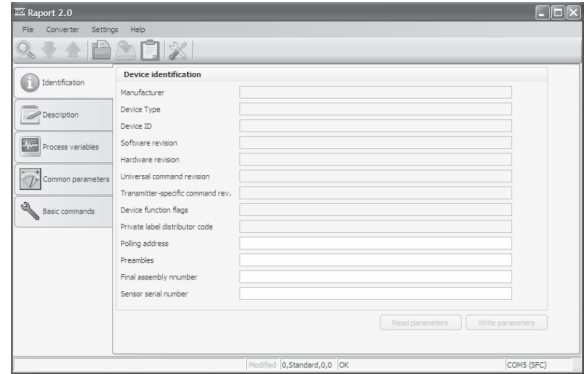

Aplisens Mobile Configurator

Aplisens Mobile Configurator is an Android application designed for communication and data transfer from transmitters with Hart or Modbus protocol made by APLISENS.

The communication with the transmitters enables:

- Supports wireless Bluetooth connection
- Read basic device information
- Configure device's Tag, Descriptor, Message, Address, etc.
- Monitor process variables
- Configure range and units
- Set/Unset write protection
- Configure specific features of pressure transmitters (LCD, alarms, transfer function, user variable)

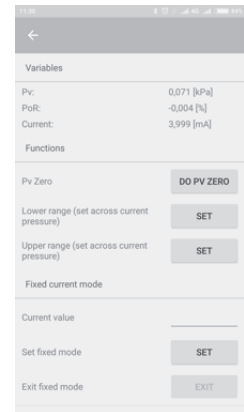
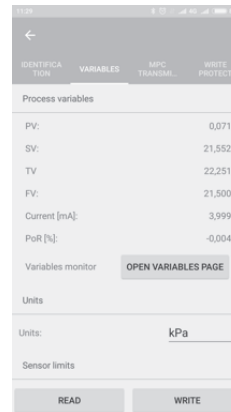

Hart Field Communicators KAP-03 and KAP-03Ex

Specification:

The **KAP-03 (KAP-03Ex)** HART field communicator is a portable battery supplied device used for communication and exchange of data with smart transmitters e. g. pressure, differential pressure transmitters. It features an output built as a standard current loop 4-20 mA, using FSK modulation type BEL 202 with an implemented HART communication protocol revision 5 and revision 6. The communicator is specially designed to configure smart transmitters manufactured by APLISENS.



Ordering procedure:

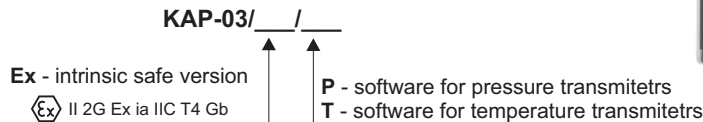

HART/USB converter

HART/USB converter allows for connecting and configuration of Hart transmitters via USB port. It works also with devices equipped in Bluetooth.



Notes

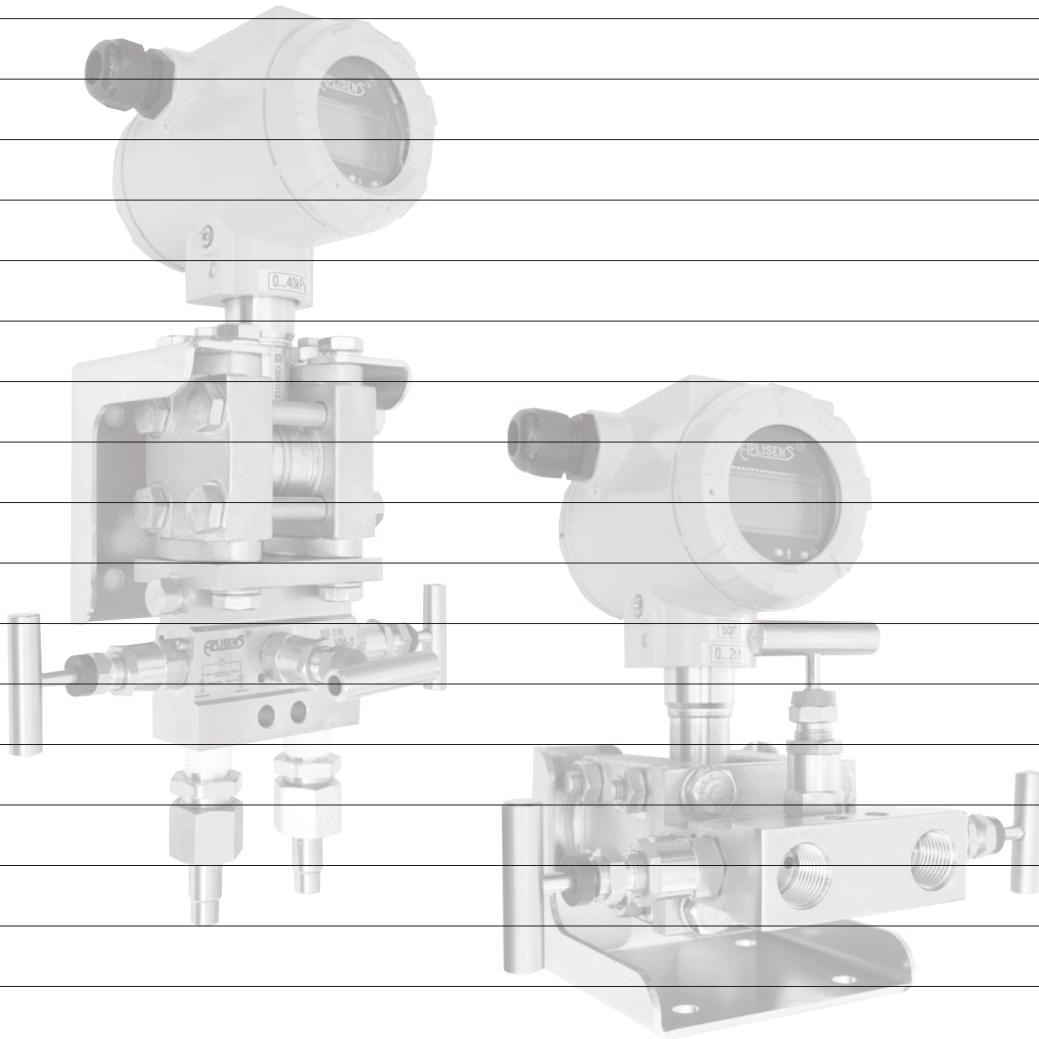

Notes

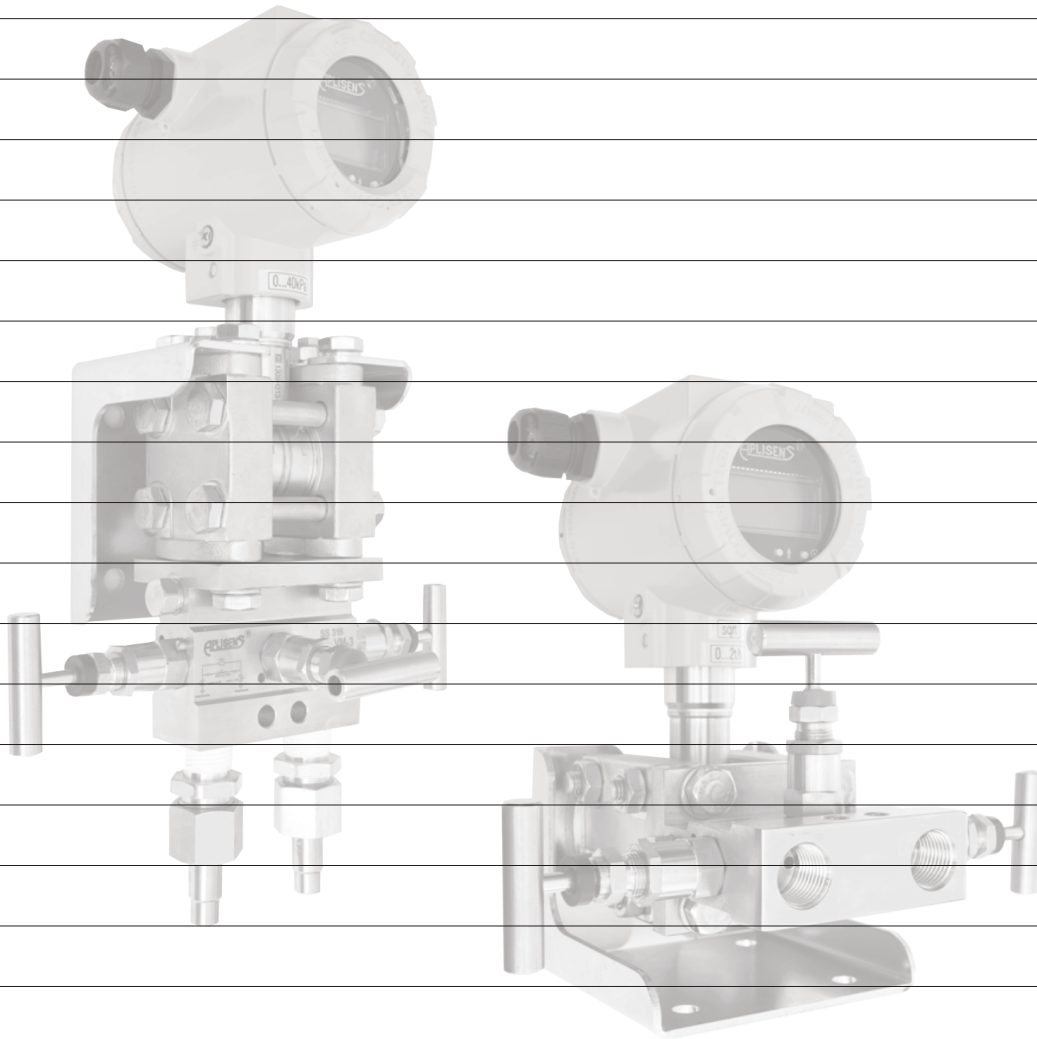

Notes

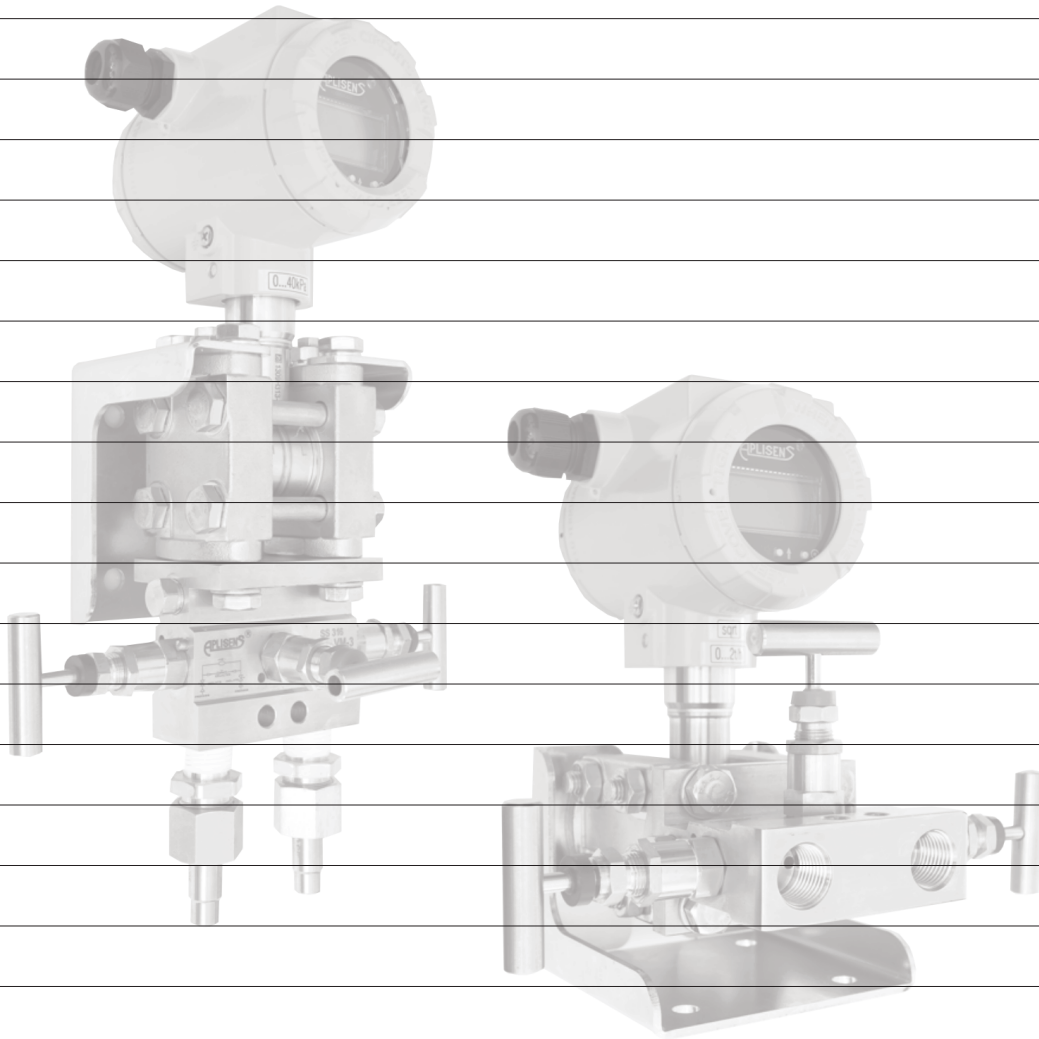

Unit Calculator

	KPa	MPa	bar	m H ₂ O	mm Hg	KG/cm ²	in H ₂ O	in Hg	psi
1 kPa =	1	0.001	0.01	0.102	7.501	0.0102	4.016	0.2953	0.14505
1 MPa =	1000	1	10	102	7501	10.2	4016	295.3	145.05
1 bar =	100	0.1	1	10.2	750.1	1.020	401.6	29.53	14.505
1 m H₂O =	9.807	0.009807	0.09807	1	73.56	0.1	39.37	2.896	1.4224
1 mm Hg =	0.13332	0.0001333	0.001333	0.01359	1	0.001359	0.5351	0.03937	0.01934
1 at = 1 KG/cm² =	98.07	0.09807	0.9807	10	735.6	1	393.7	28.96	14.224
1 in H₂O =	0.2491	0.0002491	0.002491	0.0254	1.8684	0.00254	1	0.07355	0.036126
1 in Hg =	3.386	0.003386	0.03386	0.3453	25.4	0.03453	13.60	1	0.4912
1 psi =	6.8948	0.0068948	0.068948	0.7031	51.715	0.07031	27.68	2.036	1



APLISENS[®]

APLISENS S.A.
7 Morelowa St.,
03-192 Warsaw , POLAND
Tel. +48 22 814 07 77
Fax +48 22 814 07 78
export@aplisens.com
www.aplisens.com